

ALARMBOT

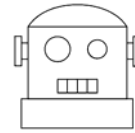

Outdoor Post Alarm • Installation Instructions

⚠ WARNING



ELECTRICAL SHOCK HAZARD

Disconnect power before installing or servicing this product. A qualified service person must install and service this product according to applicable electrical and plumbing codes.

⚠ WARNING



EXPLOSION OR FIRE HAZARD

Do not use this product with flammable liquids. Do not install in hazardous locations as defined by National Electrical Code, ANSI/NFPA 70.

Failure to follow these precautions could result in serious injury or death. Replace product immediately if switch cable becomes damaged or severed. Keep these instructions with warranty after installation. This product must be installed in accordance with National Electric Code, ANSI/NFPA 70 so as to prevent moisture from entering or accumulating within boxes, conduit bodies, fittings, float housing, or cable.

1. Choose a mounting location with maximum visibility of visual alarm.
2. The AlarmBot outdoor post alarm mounts onto the end of a 4" PVC electrical conduit. The other end of the conduit is buried in the ground. You will need to decide whether you want to run the pump wire, incoming power, and float wire feeds into the conduit through a hole drilled into the conduit or up through the bottom of the conduit (either way is acceptable). When selecting the length of conduit required, take into account both the height you want to mount the alarm and the buried depth you require for stability. Take into account the stability of ground conditions, local weather, erosion, buried utilities, and local codes when choosing a bury depth. Seal conduit off from any sewer gases, as gases could corrode exposed wiring and insulation.
3. Bring your incoming power, pump power cord, "piggyback" pump float, and alarm float wires through the center of the conduit. Allow enough slack for the AlarmBot housing to be lifted off the conduit for access to wiring connections.
4. Make wiring connections according to the attached Field Wiring Diagram. For incoming power and alarm float(s), use twist-on wiring connectors. If you are only bringing in a single 115V power feed (alarm power and pump power not separate) then connect both black wires together and both white wires together. If using a "piggyback" pump float, insert the float plug into the outlet, and then insert the pump cord plug into the float plug. If the pump has an integrated control float, insert the pump cord plug directly into the outlet. **Maximum pump current is 15.0 FLA.** Be sure to follow any local electrical codes requiring separate power feeds for alarm power and pump power; if not powered separately, a pump fault could cause loss of alarm functionality.
5. If desired, follow instructions on the last page of these instructions to drill conduit vent holes in lower section of AlarmBot housing. This step is optional.
6. Place the alarm onto the end of the conduit, making sure all wires and cords are down inside the conduit. Tighten the thumbscrew on the AlarmBot housing to secure it to the conduit. Alternatively, at the discretion of the installer, a 1/4"-20 Philips screw can be used to reduce the possibility of vandalism.
7. With all wires properly connected it's time to test the operation.
 - a. Turn on all power to the unit.
 - b. Manually tip up the "piggyback" float (or integrated pump float) to make sure that it starts and stops the pump properly.
 - c. Manually tip up the alarm float to make sure it turns on and off the audible and visual high water alarms.
8. The ON-OFF-TEST switch will control whether the audible alarm will sound. In the ON position, the audible will sound when the alarm float tips up. (The switch should typically be left in this position so that the audible will sound when a problem arises.) In the OFF position, the audible will be silenced (the alarm light will still flash any time the alarm float is tipped up). The TEST position will test the alarm light and audible as if the float had tipped up. This TEST should be periodically tried to make sure the unit is working.



ALARMBOT AB1F FIELD WIRING DIAGRAM

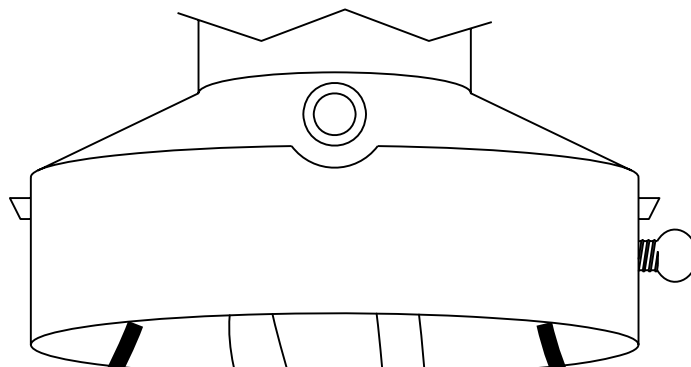

PUMP
OUTLET
15.0 FLA MAX.

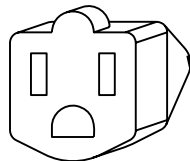

RED
RED
ALARM
FLOAT

WHITE
BLACK
NEUTRAL
LINE

GREEN
WHITE
BLACK
GROUND
NEUTRAL
LINE

ALARM POWER
115VAC-1Ø-60Hz

PUMP POWER
115VAC-1Ø-60Hz

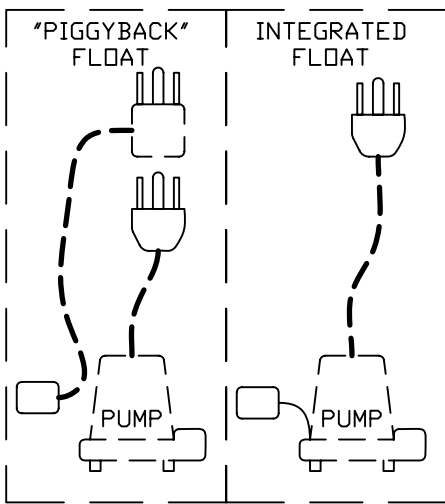

ALARM
FLOAT

NOTE:
IF ONLY USING A SINGLE
115VAC POWER SOURCE,
CONNECT BOTH BLACK WIRES
TOGETHER AND BOTH WHITE
WIRES TOGETHER.

TO WET WELL

TO POWER FEED

- NOTES:
1. MAIN POWER DISCONNECT IS TO BE PROVIDED BY INSTALLER.
 2. OVERLOAD DEVICE MUST BE IN PUMP MOTOR.
 3. USE TWIST-ON WIRING CONNECTORS FOR WIRING CONNECTIONS (TO BE PROVIDED BY INSTALLER).
 4. FIELD WIRING MUST BE 60°C COPPER WIRE MINIMUM.
 5. ----- = ITEMS NOT SUPPLIED IN CONTROL PANEL.

DRWN.	CSI controls	220 Ohio Street Ashland, Ohio (419)281-5767
DWF		
DATE	SCALE	DRWG. NO.
9/29/09	NONE	A-AB1F

TYPICAL INSTALLATION

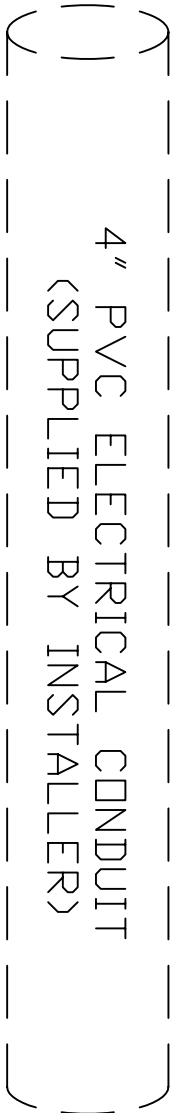
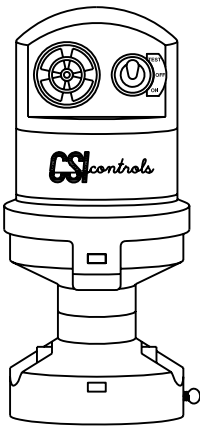

4" PVC ELECTRICAL CONDUIT
(SUPPLIED BY INSTALLER)

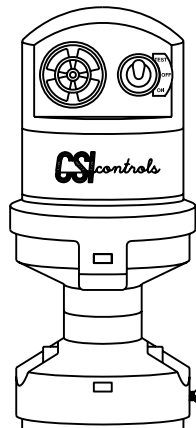

TIGHTEN THUMB
SCREW TO
SECURE ALARM
TO CONDUIT

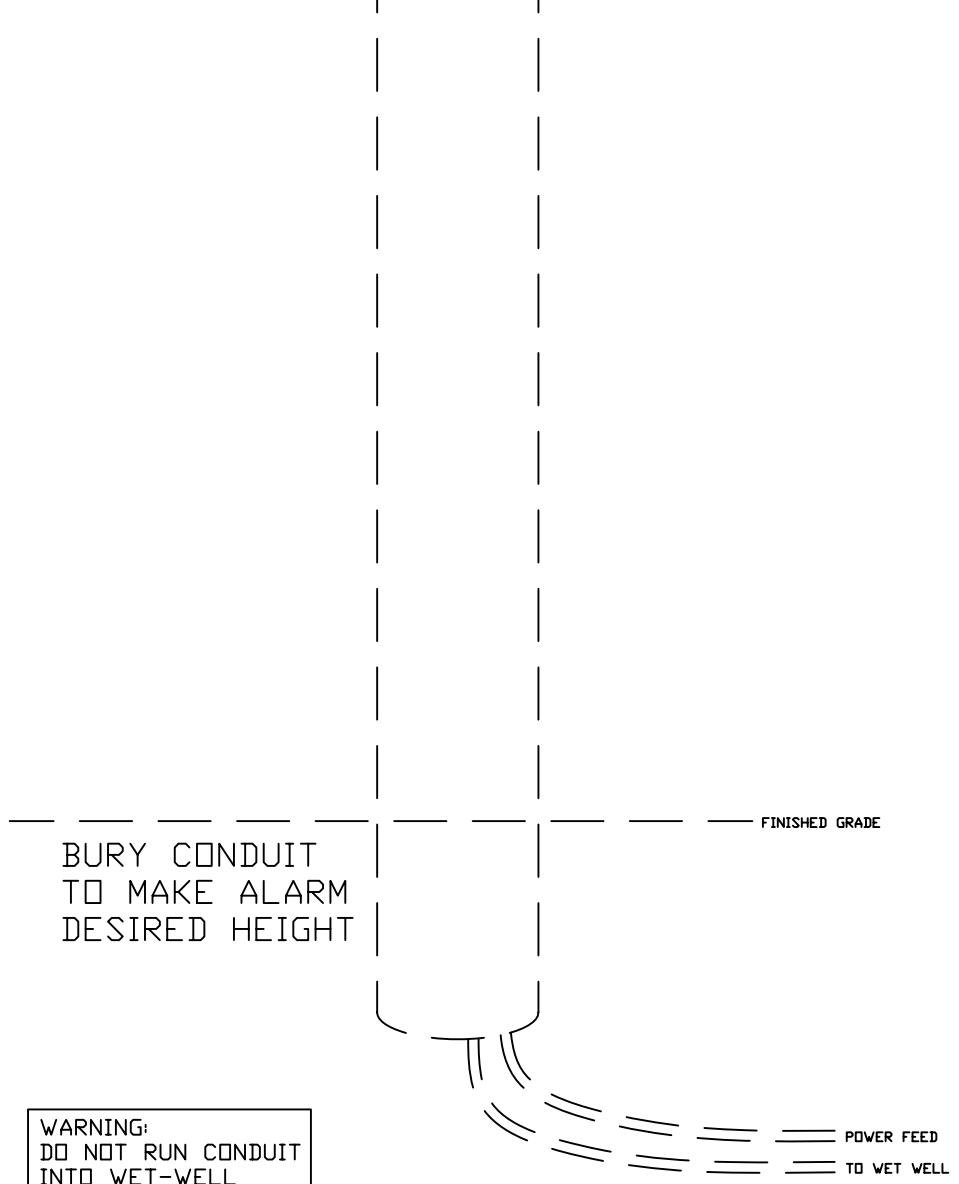

WARNING:
DO NOT RUN CONDUIT
INTO WET-WELL

DRWN.	CSI controls	220 Ohio Street Ashland, Ohio (419)281-5767	
DWF			
DATE	SCALE	DRWG. NO.	
9/29/09	NONE	A-AB1F	

Optional Conduit Vent Holes

If sewer gases leak into the vertical conduit supporting the AlarmBot, they will corrode the electrical wiring and the pump outlet contacts. If the installer desires to slow the corrosion that may result from a leak of sewer gas into the conduit, small vent holes may be drilled into the lower AlarmBot housing inside the circular threaded ports, as shown in the photograph to the lower right.

Be sure to only drill these holes in the *lower* section (the section containing the thumb screw.) The upper section is sealed and should not be exposed to the environment. **Even with these vent holes, the conduit must be sealed off from sewer gases, and any corrosion due to sewer gases WILL NOT BE COVERED UNDER WARRANTY.**

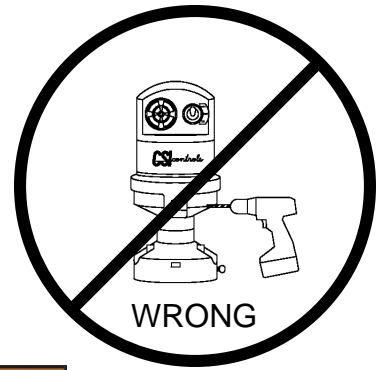
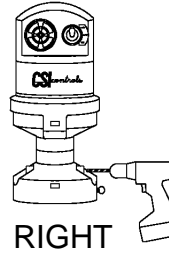

“LIMITED” WARRANTY ALARMBOT POST ALARMS



During the time period subject to the conditions hereinafter set forth, CSI will repair or replace to the original user or consumer, any portion of a CSI product which proves defective due to defective materials or workmanship of CSI. Contact your nearest authorized CSI dealer for warranty service. At all times CSI shall have and possess the sole right and option to determine whether to repair or replace defective equipment, parts, or components. Damage due to conditions beyond the control of CSI is **NOT COVERED BY THIS WARRANTY**. (Contact parcel or freight company for claims on freight damaged in transit)

WARRANTY PERIOD: CSI shall warrant its alarm systems, control panels and accessories for a period of three (3) years from the date of purchase.

LABOR, ETC., COSTS: CSI shall **IN NO EVENT** be responsible or liable for the cost of field labor or other charges incurred by any customer in removing and/or re-affixing any CSI product, part or component thereof.

THIS WARRANTY WILL NOT APPLY: (a) To defects or malfunctions resulting from failure to properly install, operate or maintain the unit in accordance with printed instructions provided; (b) to units which are not installed in accordance with applicable local codes, ordinances and good trade practices; (c) if the unit is moved from its original location, or; (d) if the unit is used for purposes other than for what it was designed and manufactured.

RETURN OF REPLACED COMPONENTS: Any item to be replaced under this Warranty must be returned to CSI at Ashland, Ohio, or such other place as CSI may designate, freight prepaid.

PRODUCT IMPROVEMENTS: CSI reserves the right to change or improve its products or any portions thereof without being obliged to provide such change or improvement of units sold and/or shipped prior to such change or improvement.

WARRANTY EXCLUSIONS: As to any specific CSI product, after the expiration of the time period of the warranty applicable thereto as set forth under the heading “Warranty Period” above. **THERE WILL BE NO WARRANTIES, INCLUDING ANY IMPLIED WARRANTIES OF MERCHANTABILITY OR FITNESS FOR ANY PARTICULAR PURPOSE.**

Some states do not allow limitations on how long an implied warranty lasts, so the above limitations may not apply to you. No warranties or representations at any time made by any representative of CSI shall vary or expand the provisions hereof.

LIABILITY LIMITATION: IN NO EVENT SHALL CSI BE LIABLE OR RESPONSIBLE FOR CONSEQUENTIAL, INCIDENTAL OR SPECIAL DAMAGES RESULTING FROM OR RELATED IN ANY MANNER TO ANY CSI PRODUCT OR PARTS THEREOF.

Some states do not allow the exclusion of limitation of incidental or consequential damages, so the above limitation or exclusion may not apply to you.

This Warranty gives you specific legal rights and you may also have other rights which vary from state to state.

Direct all notices, etc. to: Service Department
CSI Controls
220 Ohio St.
Ashland, Ohio 44805