

THE COMMANDER

Level Controller

CSLC-1501: Simplex Controller

CSLC-1502: Duplex Controller

CSLC-1503: Triplex Controller

CSLC-1504: Quadraplex Controller

CSLC-150(X)-420: Controller with 4-20mA input
(where x is a number 1-4)



Getting Started with The Commander

Congratulations! You now own THE COMMANDER! An innovative product in liquid level control.

The COMMANDER is an economical solution using state of the art solid-state circuitry to incorporate many necessary functions of today's liquid level controls. It combines the functions of a pressure transducer, an alternating relay, a lag pump time delay, a lead pump selector, and a 4-20mA output into one simple unit. The controller is also 100% intrinsically safe since there is absolutely no control power in the wet well using the standard pressure bell!

There are four standard versions of the COMMANDER. The versions are a Simplex version, for single pump control, a Duplex version, for two-pump control, a Triplex version, for three-pump control, and a Quadraplex version, for four-pump control. All versions basically operate the same, with the few differences listed in this manual. The standard versions consist of a COMMANDER controller unit, a level indicating pressure bell, and tubing to connect the controller and the bell.

All versions also have the option of using a 4-20mA, 2 wire, level transducer, instead of the standard pressure bell. A COMMANDER unit can be purchased as the standard unit with the pressure bell, or as the 4-20mA input version. The pressure bell input and the 4-20mA input are not interchangeable. Transducers for the 4-20mA input option are sold separately.

Setting Up Your Commander Level Controller

1. Mounting the Controller Unit

The COMMANDER controller unit should be mounted in a protective indoor or enclosed environment. Mounting feet and holes are on each unit. The dimensions for the controller and mounting holes are provided at the end of this manual.

2. Connecting the Pressure Tube (Standard Versions Only)

The tubing provided with the COMMANDER is durable and flexible. The tubing should still, however, be protected from being cut or pinched, since if this would occur it will cause the level sensing system to fail.

The pressure tube must be connected correctly to insure proper operation of your COMMANDER unit. First connect the tube to the pressure bell. To do this feed the tubing through the extension tube (see next section on "Mounting the Pressure Bell" for further details). After feeding the tubing through, insert the end of the pressure tube into the connector in the top of the pressure bell as shown. Then screw the extension tube on to the top of the pressure bell.

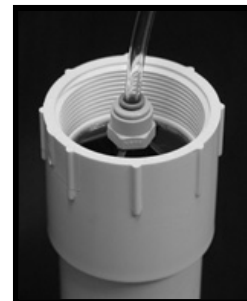

Next connect the pressure tubing to the COMMANDER controller. The tube *must* be connected to the controller when the pressure bell *is not* submerged in liquid. Simply insert the tube into the connector on the bottom of the controller box. Make sure the connector holds the tube securely. To remove the tube, push in on the colored part of the connector and pull the tube out.

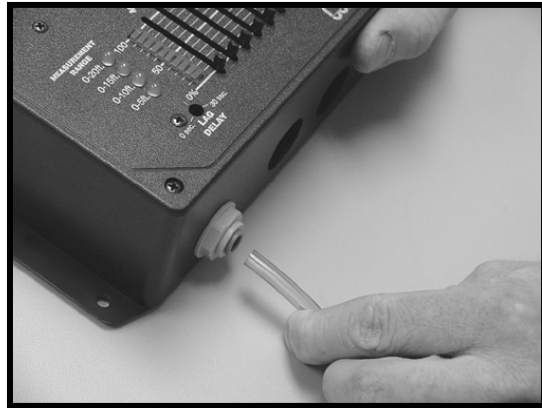

Note: The tubing must be cut squarely on the end to ensure a good, sealed, connection.

3. Mounting the Pressure Bell (Standard Versions Only)

The pressure bell should be mounted so that the zero measurement level is at the bottom of the union nut. The pressure bell was designed to make mounting and installation as easy as possible. The top of the bell has a 2" NPT female thread so that an extension tube (provided by end user) of any desired length could be added to the top of the bell to aid in mounting it. Enough slack pressure tubing should be left at the top of the extension tube to allow the pressure bell to be pulled out of the basin.

Typical Installation

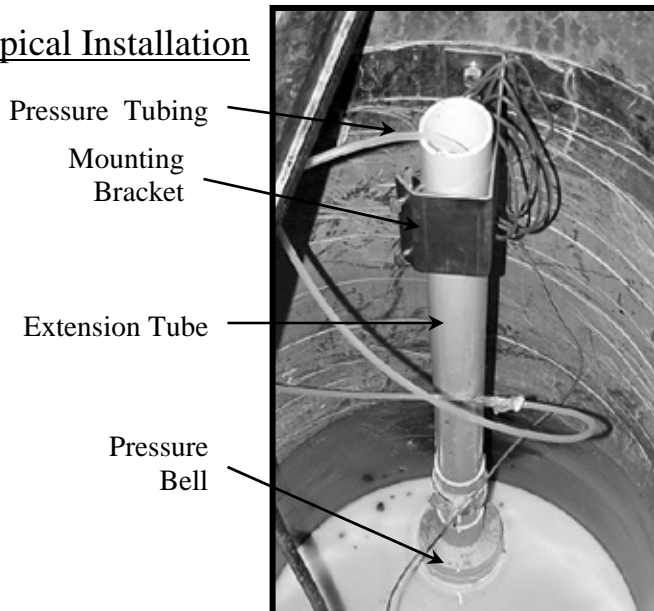

Pressure Bell

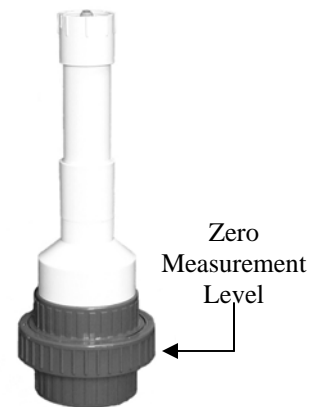

4. Connecting 4-20mA input (4-20mA input Versions Only)

The COMMANDER models CSLC-150(X)-420 have a connection for a 4-20mA input. This input has an internal loop power supply. Mount the transducer as directed by the manufacturer. The 4-20mA signal should be carried on a twisted,

shielded wire pair. To connect it to the COMMANDER simply connect the positive lead from the transducer to the positive terminal of the “Transducer Input”, and the negative lead from the transducer to the negative terminal of the “Transducer Input. The shield should be connected to earth ground at one point only.

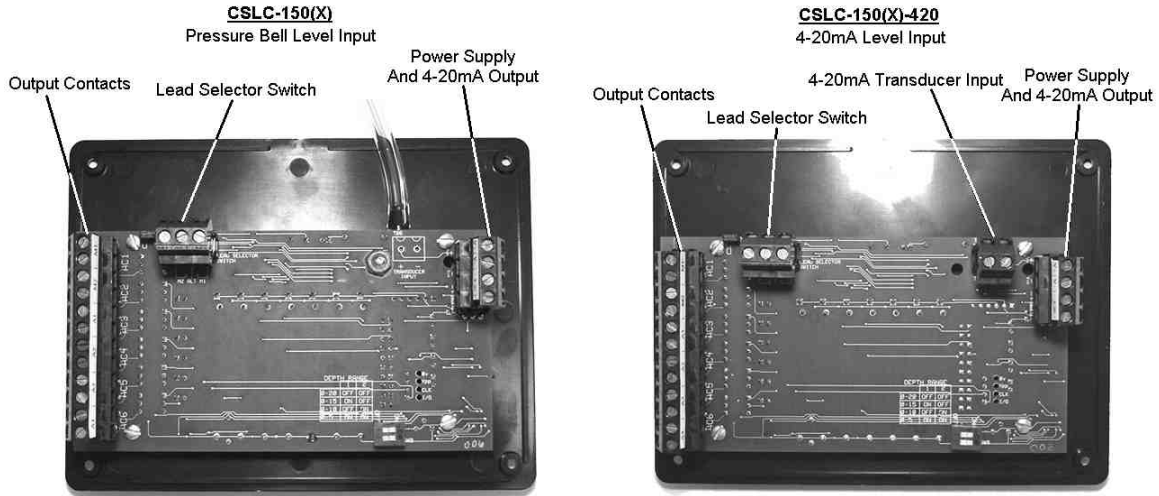

Terminal Block Locations

5. Connecting to the System

The Commander will need to be connected to the system next. To connect the wires to the controller remove the lid of the controller by removing the four corner screws. There are labeled terminal blocks on the back of the printed circuit board (PCB) that all connections will be made to.

▪ Power Supply

First connect the power supply to the controller terminal blocks. Use either the power supply provided with the COMMANDER, or a supply that conforms to the electrical ratings at the end of this manual. The power supply connections will be labeled simply V+ and V- (The 4-20mA loop is also labeled with a + and -, but has **4-20mA** between the + and -, see section “4-20mA Output” for instructions on connecting to these terminals). The completely black lead (the negative lead) from the supplied DC wall transformer should be connected to the V- terminal block. The black lead with a white stripe (the positive lead) should be connected to the V+ terminal block. **Be careful to connect the power supply correctly, reversing the leads will cause THE COMMANDER to not function and could cause permanent damage to the unit!** Do not plug in the power supply transformer until all the wiring is completed.



- **Output Contacts**

Next connect any motor contactors, control relays, or control circuitry as necessary. *The Level Controller can only switch AC voltages less than or equal to 120VAC, and currents less than or equal to 0.5A_{RMS}.* These connections are to be made to the six terminal blocks that correspond to the outputs. These will be labeled differently according to the model you are using. Table 1 shows how each of the models will be labeled.

Simplex	M1	A1	A2	A3	A4	A5
Duplex	M1	M2	A1	A2	A3	A4
Triplex	M1	M2	M3	A1	A2	A3
Quadraplex	M1	M2	M3	M4	A1	A2

Table 1.

Each output has two connections that can be connected as a dry, normally open, contact would be. An example of the connection schematic is shown in Figure 1 on page 6.

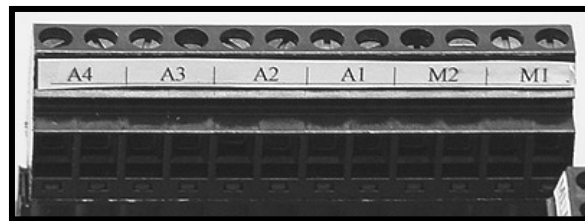

Note: The electronic output contacts will leak a small amount of current. Depending on the application a small slave relay may be necessary to eliminate unwanted triggering of equipment with sensitive inputs.

It is suggested that one of the outputs be used as a low level / low pressure alarm. This would alarm if the pressure bell would lose pressure due to an air leak or a puncture in the airline or bellofram (the durable rubber diaphragm on the pressure bell). An external relay would be required in a typical alarm circuit (See schematic example page 6).

- **Lead Selector Switch**

If you are using a duplex, triplex, or quadraplex model COMMANDER, lead selection of the pump outputs is as easy as adding a switch. The controller will always default to automatic alternation. If lead selection is required, a lead selector switch (not furnished) may be added.

Duplex COMMANDER

The terminal block for this switch is labeled **Lead Selector Switch** with three connections, **M1**, **ALT** and **M2**. A three-position toggle switch should be used as the selector switch. An example of how this is connected can also be seen in Figure 1 on page 6.



Triplex COMMANDER

The terminal block for this switch is labeled **Lead Selector Switch** with three connections, **1**, **COM** and **2**. A four-position switch should be used as a selector switch. It is recommended that you contact CSI controls for assistance in obtaining the correct selector switch. Table 2 indicates the switch contact configuration and the resulting motor sequence selection.

	COM-2	COM-1
Alternate	OFF	OFF
M1-M2-M3	OFF	ON
M2-M3-M1	ON	OFF
M3-M1-M2	ON	ON

Table 2.

Quadruplex COMMANDER

Lead selection is available for the Quadruplex COMMANDER. Please contact CSI controls for information and assistance in adding switches for this feature.

▪ 4-20mA Output

The COMMANDER contains a 4-20mA loop output. This output can be used to indicate liquid level (4mA = 0% level, 20mA = 100% level) to a Variable Frequency Drive, a Programmable Logic Controller, or other industrial control equipment. If necessary, connect the 4-20mA loop next. This 4-20mA loop is powered from the COMMANDER board, so *no external power supply should be connected to the 4-20mA output loop*. The terminal blocks for the 4-20mA are labeled + and – with **4-20mA** underneath. The + terminal is the 4-20mA source and the – terminal is the 4-20mA return. The – terminal is common with the power supply – terminal. A twisted, shielded wire should carry the 4-20mA signal, with the shield connected to earth ground at one point only.

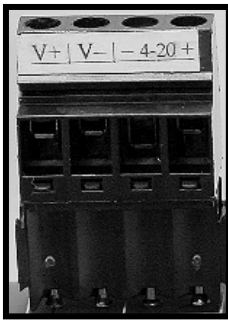

With the standard COMMANDER 9V power supply the maximum 4-20mA loop resistance is 280 ohms. If a larger loop resistance is required the 9VDC supply can be replaced with a 24VDC power supply, which will allow a loop resistance of 1030 ohms. *Under no circumstances should an AC power supply adapter be used, or a DC power supply which exceeds 24VDC.* See section on the **Power Supply** for further details.

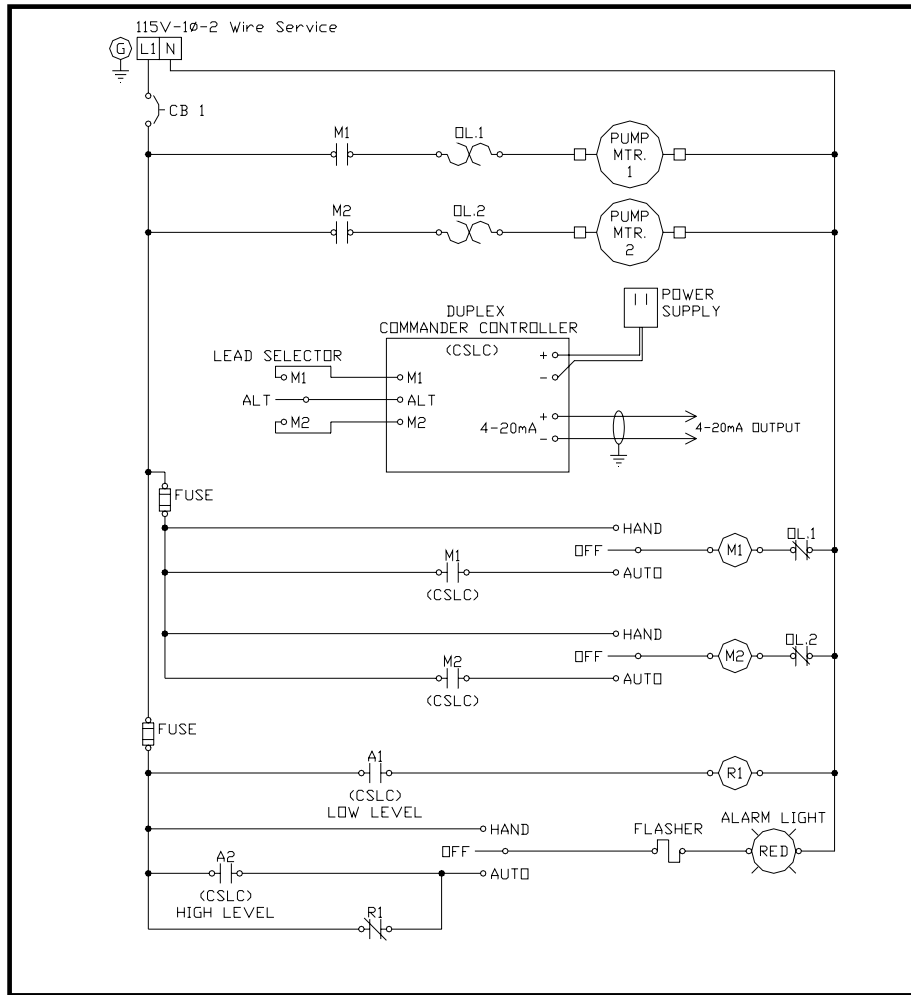
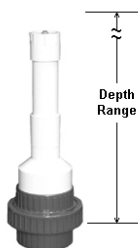
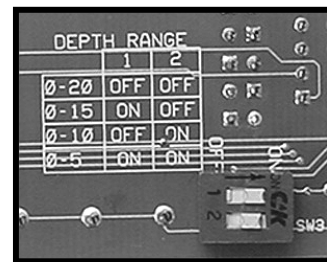

Figure 1. Schematic Example

Using Your Level Controller

1. Setting the Depth Range

The level controller has a selectable depth range. The level controller can measure a depth range of 0'-5', 0'-10', 0'-15', and 0'-20'. The dipswitches on the back of the PCB select this setting. Table 3 shows what depth range setting each of the dipswitch settings select. The yellow LEDs on the front of THE COMMANDER will confirm your depth range setting.



Switch 1	Switch 2	Depth Range
ON	ON	0'-5'
OFF	ON	0'-10'
ON	OFF	0'-15'
OFF	OFF	0'-20'

Table 3.

2. Setting Level Set Points

The slide potentiometers select the percentage of the total depth range that the set point will switch at. For example, if your level controller is a duplex version, the **LEAD** and **LAG** slides select the level that the lead pump and lag pump turn on at. The **MTRS. OFF** slide selects the level that both pumps turn off at. The **AUX CONTACTS** slides each set an on/off set point. In duplex mode the **LEAD** and **LAG** slides correspond to terminal block outputs **M1** and **M2** (which is lead and which is lag depends on alternation and the Lead Selector Switch). **AUX CONTACTS 1, 2, 3,** and **4** correspond to terminal block outputs **A1, A2, A3,** and **A4** respectively.

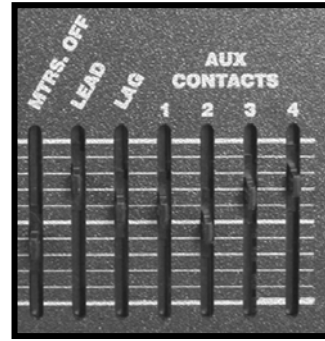

For the triplex version the **LEAD, LAG1,** and **LAG2** slides correspond to terminal block outputs **M1, M2,** and **M3** (which is lead and which is lag depends on alternation and the Lead Selector Switch). **AUX CONTACTS 1, 2,** and **3** correspond to terminal block outputs **A1, A2,** and **A3**.

For the quadraplex version the **LEAD, LAG1, LAG2** and **LAG3** slides correspond to terminal block outputs **M1, M2, M3** and **M4** (which is lead and which is lag depends on alternation and the Lead Selector Switch). **AUX CONTACTS 1** and **2** correspond to terminal block outputs **A1** and **A2**.

The COMMANDER controllers are designed for pump down operation only. Like setting floats, you want the “lead” above the “off” setting, and the “lag” above the “lead” setting. However, if any lag pump setting is below the previous lag pump setting or the lead pump setting the controller will automatically change it’s setting to equal the previous pump’s setting. Also if the lead (or M1 ON for simplex) setting is below the off setting the controller will automatically set it equal to the off setting.

3. Setting the Lag Delay

If your level controller is a duplex, triplex, or quadraplex model the lag pump(s) have an adjustable time delay. The delay time can range from 0-30 seconds. The **LAG DELAY** dial can be adjusted with a small flat head screwdriver.



To set the delay to 0 seconds turn the dial completely counter-clockwise. To set the delay to 30 seconds turn the dial completely clockwise. The time delay can be set anywhere between 0 and 30 seconds by turning the dial proportionally to the desired delay. For the triplex and quadraplex models, each pump will sequentially turn on with a lag delay in between. For example, if a quadraplex station lost power and the level rose to the **LAG 3** setting, when power was restored the pumps would turn on in the following fashion. Lead pump on – time delay – Lag pump 1 on – time delay – Lag pump 2 on – time delay – Lag pump 3 on.

4. The Indicator Lights

The COMMANDER has three types of indicating lights. Measurement range indication lights, liquid level indication lights, and output status indication lights. The measurement range light indicates which measurement range the controller is set for. To change this setting, see the section on “Setting the Depth Range.”

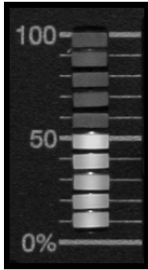
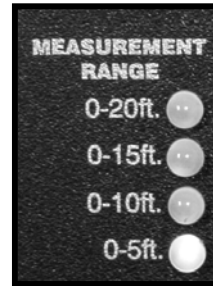

The liquid level lights indicate the liquid level in a bar graph fashion, at 10% increments. This can give you a general idea of the tank liquid level without actually having to look into the tank.

The controller has an indicator light corresponding to the output status of each terminal block output. The lights will either be Red or Green, indicating that the output is off or on respectively. These lights will always be lit either red or green when there is power to the controller.

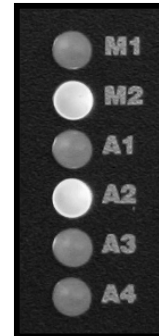

Dimensions

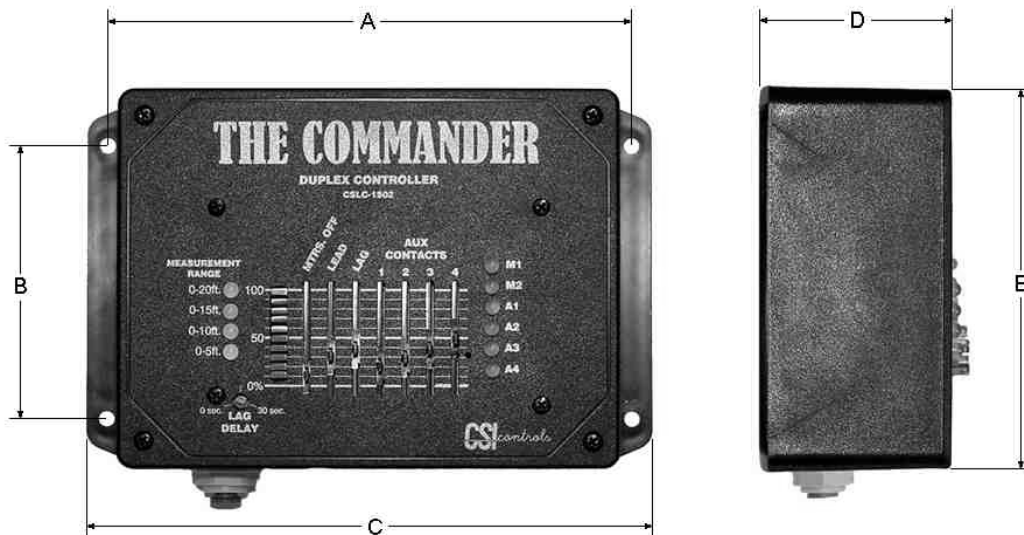

Mounting Holes

A: 6.75"
B: 3.50"

Enclosure Size

C: 7.275"
D: 2.255"
E: 4.61"

Specifications and Ratings

	Simplex	Duplex	Triplex	Quadraplex
Power Supply	UL class II power supply. Output Voltage: 9 VDC – 24 VDC Output Current: 200mA minimum			
Output Contact Ratings	Voltage: 12 VAC – 120 VAC Current: 30mA - .5A continuous (r.m.s.) 4A surge current for less than 1 sec.			
4-20mA Output Impedance	Power Supply = 9 VDC: 280 ohms. Power Supply = 24 VDC: 1030 ohms.			
Pressure Input (CSLC-150(X) versions)	Min.: 0 psi Max.: 7.25 psi Max. Overpressure: 29 psi			
4-20mA Input (CSLC-150(X)-420 versions)	Internal Supply Voltage = Power Supply Voltage Internal Loop Resistance = 50 ohms.			
Operating Temperature Range	-40°F (-40°C) – +185°F (+85°C)			
Humidity	95% non-condensing			
# of Pumps to Control	1	2	3	4
# of Alarm Points	5	4	3	2



220 Ohio Street • Ashland, OH 44805
(419) 281-5767 • Fax (419) 289-2535

www.CSIcontrols.com • csi.info@CSIcontrols.com