

Titan Series

Float Operated Pump Controllers



By CSI Controls

User's Manual

Typical Simplex Float Installation

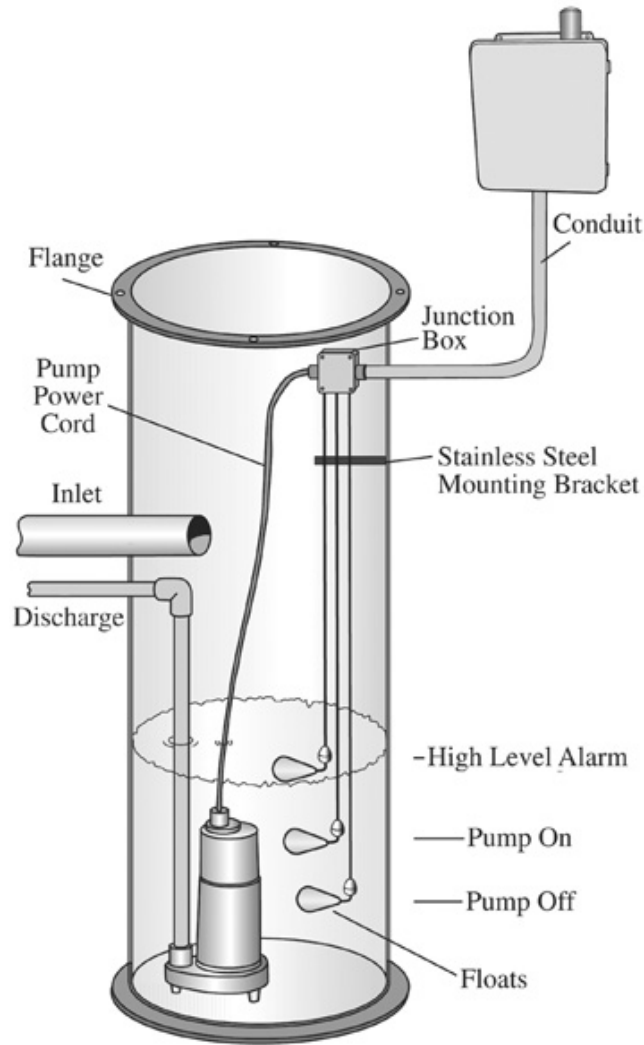

Note: Care should be taken to insure that sewage gases are not allowed to enter the control panel, seal panel with an approved sealing means! (Damage caused by sewage gas is not covered by warranty).

Installing the Floats

1. There are many different options to mounting floats. The installer can simply tie wrap or strap the floats to the pump discharge pipe at the appropriate levels using a heavy duty tie wrap or a clamp designed for that use. Floats can also be installed using a float mounting bracket w/cord snubbers and float weights as shown above.

Warning: 1. Do not install a float switch in direct line of incoming liquid.
2. Make sure you leave at least 3.5 inches of tether length between the actual float and the clamping device to allow the float to tip properly.

Wiring

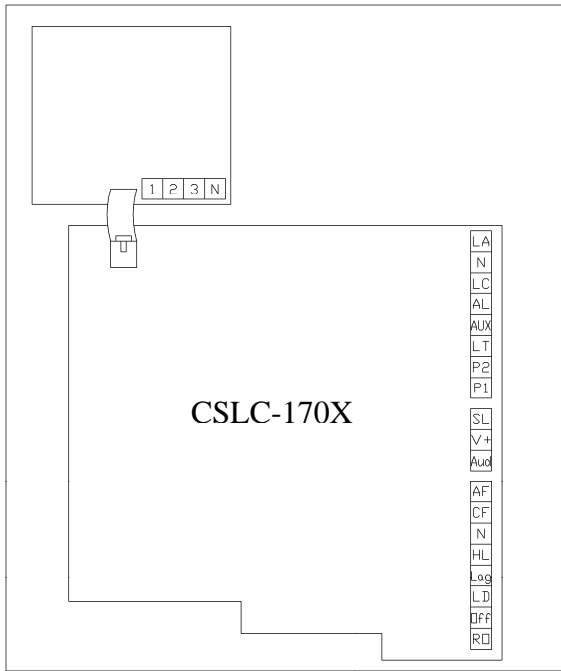

Terminal	Description
LA	Alarm Power Input, 120Vac
N	Neutral Input
LC	Control Power Input, 120Vac
AUX, AL	Auxiliary HL alarm dry contact
LT	Alarm Light output, 120Vac
P2	Pump 2 Output, 120Vac
P1	Pump 1 Output, 120Vac
SL	Silence Detection Input
V+	+12Vdc (Unregulated)
Aud	Audible Alarm output (Open Collector Output)
AF	Power to Alarm Float (100mA fused, Auto
CF	Power to Control Floats resetting)
N	Neutral for Float Power (jump to incoming neutral)
HL	Return for High Level Float
Lag	Return for Lag Pump Float
LD	Return for Lead Pump Float
Off	Return for Pumps Off Float
RO	Return for Redundant Off Float
1	Pump 1 Overload / Overtemp
2	Pump 2 Overload / Overtemp
3	Auxiliary Alarm Input
N	Neutral

Sample Wiring Diagram

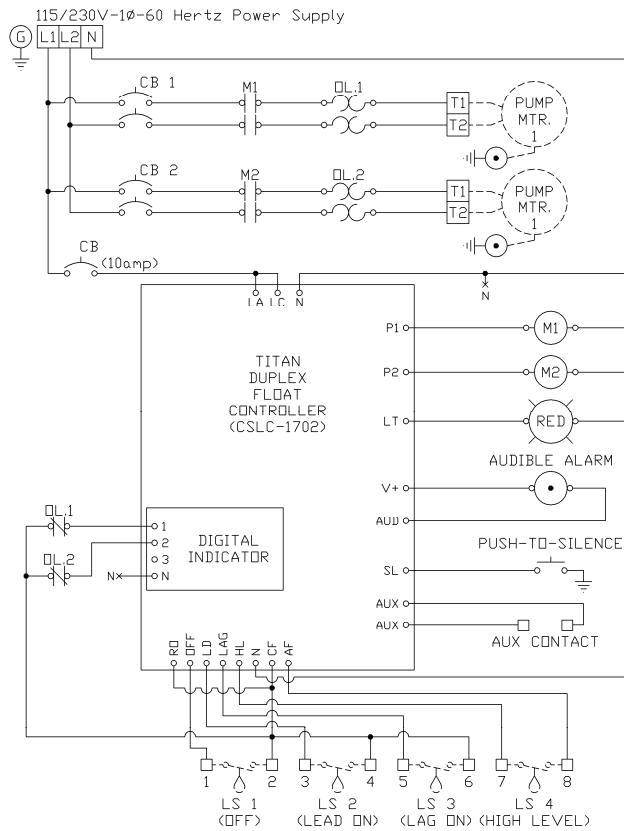

Controller Operation

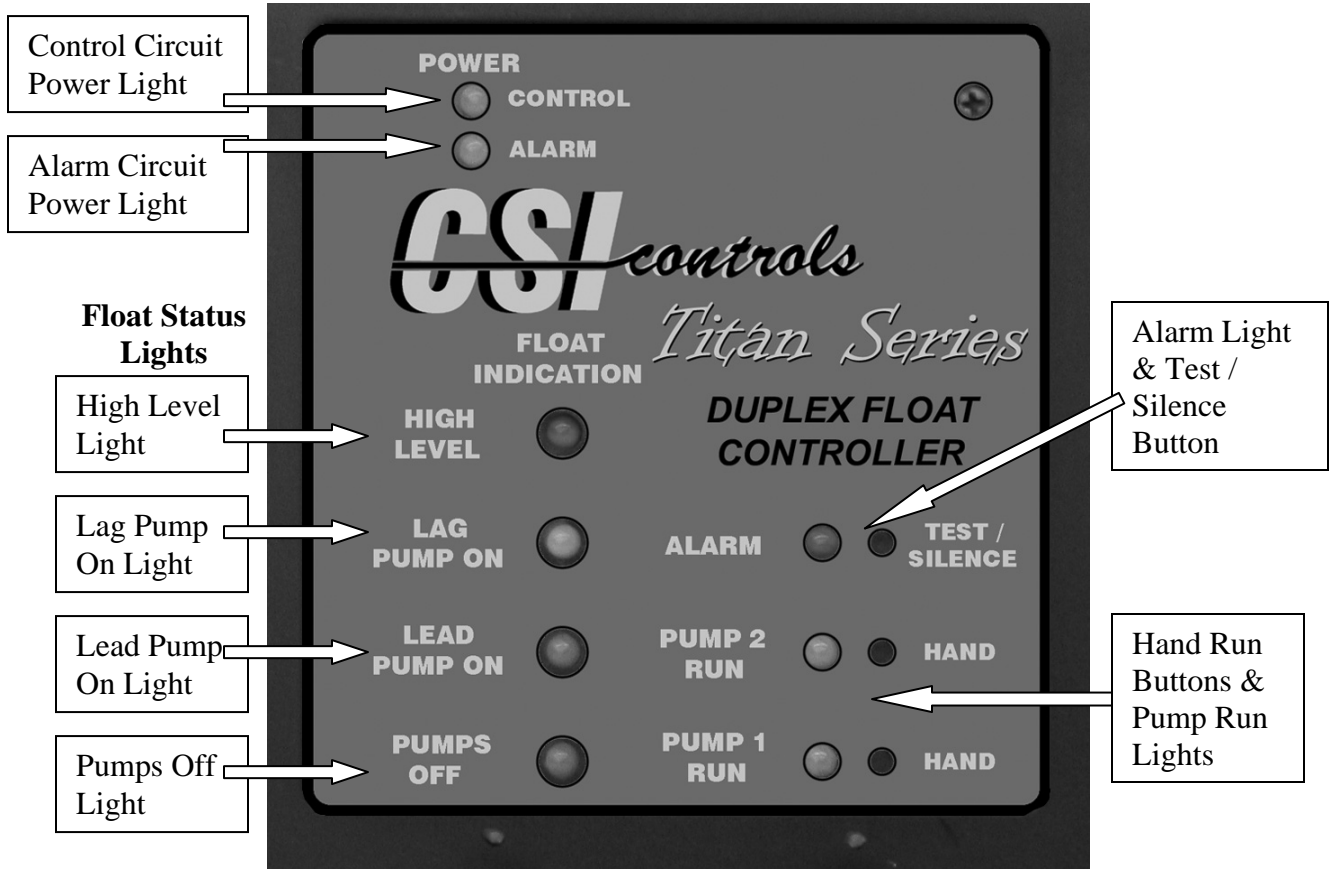

Float Status Indication Lights

Float indication lights show the status of the floats in the basin. If a float is tipped closed the corresponding LED will be lit. If the floats tip out of sequence it will cause the float indication lights to flash an error. These lights help to assist in troubleshooting float errors and station problems.

Float Failure Routine

The Titan float controllers attempt to detect when a system float has failed. The controller does this by assuming the floats are hung in the correct order in the basin.

Expected Order of Floats in Basin

Simplex Panel

High Level Float
On Float
Off Float

Duplex (or Time Dose) Panel

High Level Float
Lag (or Override) Float
Lead (or Enable) Float
Off Float

The program looks for a float to change its state from Open to Closed or Closed to Open, and assumes that a changing state indicates that the float is working. The program then looks at the state of the other floats to see if they are Open or Closed as expected. If a float is not in the expected state the program marks that float as failed. The failure for the float will be cleared if its state ever changes, or if power is cycled and the problem is corrected.

Hand-Off-Auto Operation

The “HAND” button on the Titan controller works similarly to a traditional H-O-A toggle switch. There are three modes that each pump can be in: Hand, Off, and Auto. In Off mode, the pump is disabled and will not run. To show that the pump is disabled and will not run, its respective Pump Run LED will flash. In Auto mode, the pump(s) will run as described in the sections below. In Hand mode, the pump will run regardless of the Pump On setpoint or the Time Dosing timers.

The first time the “HAND” button is pressed, the pump status on the LCD screen will flash, showing that it is being edited. Pressing “HAND” again will cycle through the three pump options. When the button has not been pushed for 3 seconds, the pump will be put into the mode that is displayed, and the text will stop flashing. When the pump is running in Hand, you may bring it out of Hand by pushing the “HAND” button one time, at which point the pump will return to its previously set mode. To protect the pump against running dry, the controller will not latch into Hand mode if the liquid level is below the Off float. To force the pump to run in Hand mode after this point, you must push and hold the “HAND” button.

Also, if the pump’s overload/overtemp input opens, the pump will be disabled and flash the Pump Run LED just as in the Off mode. In this case, the alarm will sound and the pump status on the display will show “Fail.”

The operation detailed below is considered standard operation. Standard operation may be modified by some controller settings. See “Menus” section for more details.

Basic Operation, (Standard Simplex Controller)

When the liquid level in the basin rises to the Pump On Float, the pump will turn on. The pump will stay on until the liquid level is below the Pump Off Float. If the liquid level gets all the way up to the High Level Float, the high level alarm will sound the audible and flash the alarm light. To silence the audible, press the TEST/SILENCE button on the face of the controller, or use an external switch to connect the SL terminal to ground (see sample wiring diagram).

Basic Operation (Standard Duplex Controller)

When the liquid level in the basin rises to the Lead Pump On Float, the lead pump will turn on. The pump will stay on until the liquid level is below the Pumps Off Float. After the pump turns off, the pumps will alternate. (For example, if Pump 1 was the lead pump, after it turns off Pump 2 will be the new lead pump, and Pump 1 will now be the lag pump.) However, a permanent Lead Pump may be assigned in the Level Control Options Menu. If the liquid level gets all the way up to the Lag Pump On Float, the lag pump will also turn on. A non-adjustable delay causes the Lag Pump to wait 10 seconds to turn On after the Lead Pump turns On. If the liquid level gets all the way up to the High Level Float, the high level alarm will sound the audible and flash the alarm light. To silence the audible, press the TEST/SILENCE button on the face of the controller, or use an external switch to connect the SL terminal to ground (see sample wiring diagrams).

Basic Operation (Simplex Time Dosing Controller)

When the liquid level in the basin rises to the Pump On Float, the pump will turn on. The pump will stay on until the liquid level is below the Pump Off Float, or until the Pump On timer expires, whichever comes first. The pump will then not be allowed to run again until the Pump Off timer expires *and* the liquid level is above the Pump On Float. If the liquid level gets all the way up to the High Level Float, the pump will turn on regardless of the state of the Pump Off timer. This is called a Timer Override. The pump will run for the Override On time, or until the liquid level is below the Pump Off Float, whichever comes first. After it turns off, the Override Off timer will begin, and the pump will not be allowed to run again until it expires, even if the liquid level rises above the High Level Float again. The high level alarm is also activated by the High Level Float, after the adjustable High Level Time Delay. This delay allows the Timer Override time to pump the liquid down below the high level before it alarms. To silence the audible, press the TEST/SILENCE button on the face of the controller, or use an external switch to connect the SL terminal to ground (see sample wiring diagrams).

Basic Operation (Duplex Time Dosing Controller)

When the liquid level in the basin rises to the Lead Pump On Float, the lead pump will turn on. The pump will stay on until the liquid level is below the Pump Off Float, or until the Pump On timer expires, whichever comes first. The pump will then not be allowed to run until the Pump Off timer expires. After the pump turns off, the pumps will alternate. (For example, if Pump 1 was the lead pump, after it turns off Pump 2 will be the new lead pump, and Pump 1 will now be the lag pump.) If the controller is in 2-field mode, the new lead pump will be able to run as soon as the level rises back up to the Lead Pump On Float. In 1-field mode, no pump can run until the Off timer of *both* pumps has expired. If the liquid level rises to the Lag Pump On Float, the pump will turn on regardless of the state of the Pump Off timer. This is called a Timer Override. In 2-field mode, the lag pump will also turn on after a 10-second lag delay. The pump(s) will run for the Override On Time, or until the liquid level is below the Pump Off Float, whichever comes first. After it turns off, the Override Off timer will begin, and the pump(s) will not be allowed to run again until it expires, even if the liquid level rises above the Lag On Float again. If the liquid level rises all the way up to the High Level Float, the High Level alarm will sound the audible and flash the alarm light. To silence the audible, press the TEST/SILENCE button on the face of the controller, or use an external switch to connect the SL terminal to ground (see sample wiring diagrams).

Redundant Off Float Operation

The default operation of the Redundant Off float is to disable the automatic pump run operation when the float tips down. If a Redundant Off float is not to be used, this input should be jumped out to the CF terminal. Special programming of the Titan controller may alter the operation of this float input.

Menus

Display Menu

Settings Menu

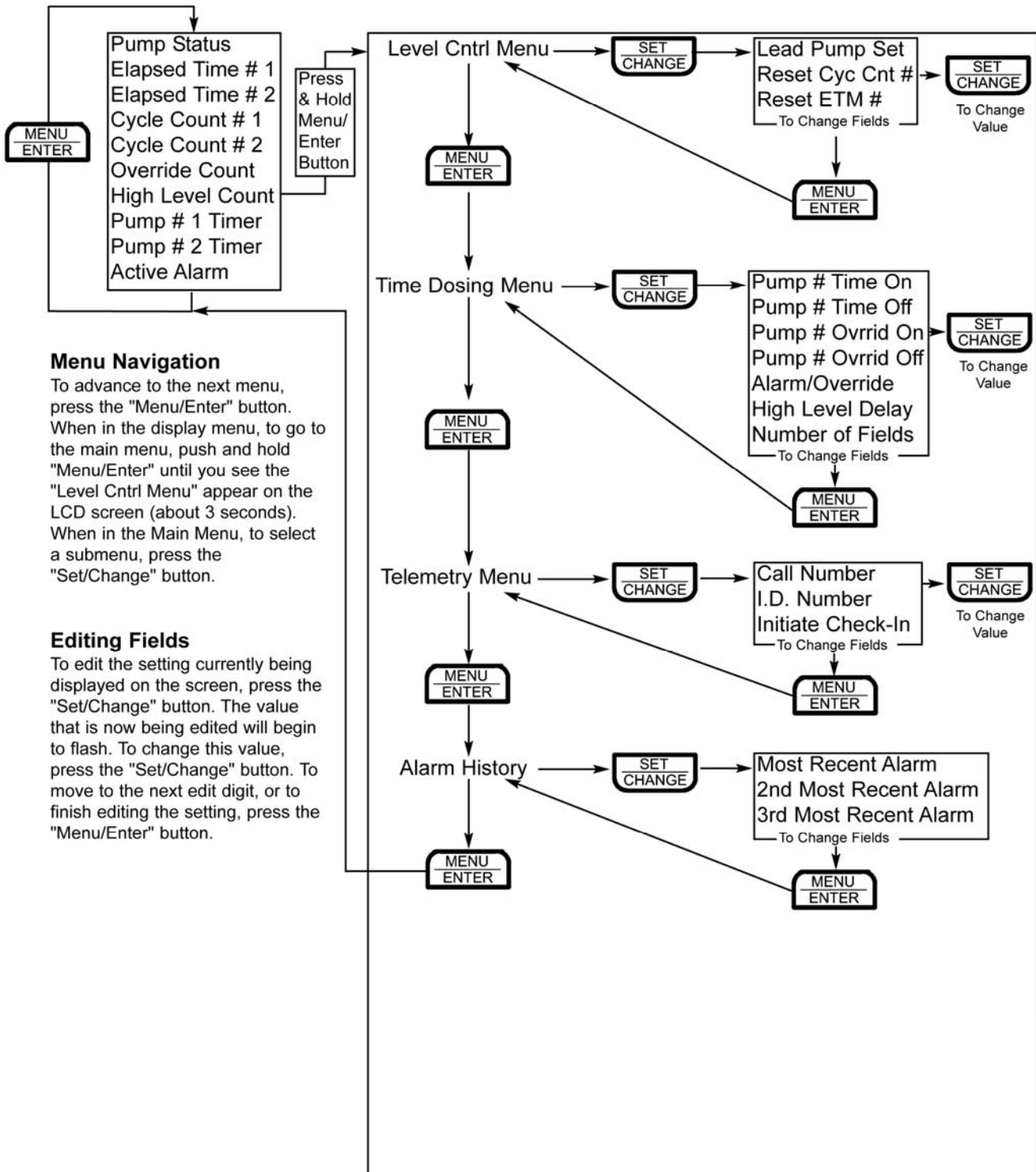

Menu Navigation

To advance to the next menu, press the “Menu/Enter” button. When in the display menu, to go to the main menu, push and hold “Menu/Enter” until you see the “Level Cntrl Menu” appear on the LCD screen (about 3 seconds). When in the Main Menu, to select a submenu, press the “Set/Change” button.

Editing Fields

To edit the setting currently being displayed on the screen, press the “Set/Change” button. The value that is now being edited will begin to flash. To change this value, press the “Set/Change” button. To move to the next edit digit, or to finish editing the setting, press the “Menu/Enter” button.

Display Menu

Press Menu/Enter Button to change between menu fields

Pump Status

Shows pump mode: Hand, Off, Auto, or Fail
(Fail shows during overload or overtemp)

Elapsed Time # - (# is Pump number (1 or 2)):

Reads out the total elapsed run time of the corresponding pump.
(Max Value 999999:59:59)

Time shown is in the format of [Hours:Minutes:Seconds.]

Cycle Count # - (# is Pump number (1 or 2)):

Reads out the number of cycles the corresponding pump has run. (Max Value: 999999)

Override Count - (Time Dose Controllers only):

Reads out the number of times the panel has gone into override mode.
(Max Value: 999999)

High Level Count -

Reads out the number of times the liquid level has reached high level.
(Max Value: 999999)

Pump # (1 or 2) Timer - (Time Dose Controllers only):

Reads out the remaining time in the current time cycle. If the pump is running then it indicates the time remaining until the pump shuts off. If the pump is off then it indicates time remaining until the pump may run again.

Active Alarm

Reads out what alarm condition the panel is currently experiencing. If there are no alarms, it will read “None”

User Settings Main Menu

Press and hold Menu/Enter Button for 3 seconds while in the Display Menu to enter into this menu. Press the Menu/Enter Button to change between menu fields.

Level Cntrl Menu - (Level Control Options Menu):

Press Set/Change button to enter into this sub-menu.

Time Dosing Menu - (Time Dosing Options Menu, Time Dose Controllers only):

Press Set/Change button to enter into this sub-menu.

Telemetry Menu - (Modem option only):

Press Set/Change button to enter into this sub-menu.

Alarm History

Press Set/Change button to enter into this sub-menu.

Level Control Options Menu

Lead Pump Set (Duplex Controllers Only):

Press Set/Change button to change this field.

Possible Settings:

Alternate = Alternate which pump turns on at the lead setpoint every time a pump runs

Pump 1 is Lead = Pump #1 always turns on at the lead pump setpoint.

Pump #2 always turns on at the lag pump setpoint.

Pump 2 is Lead = Pump #2 always turns on at the lead pump setpoint.

Pump #1 always turns on at the lag setpoint.

Reset Cyc Cnt # - This is the cycle count that can be viewed in the Display Menu (Reset Cycle Counter to zero, # is Pump number (1 or 2))

Press Set/Change button to change this field.

Possible Settings:

Do Not Reset = Cycle Counter will not reset

Reset Counter = Cycle Counter will reset to 0

Reset E.T.M. # - This is the Elapsed time that can be viewed in the Display Menu (Reset Elapsed Time to zero, # is Pump number (1 or 2))

Press Set/Change button to change this field.

Possible Settings:

Do Not Reset = Elapsed Time will not reset

Reset Counter = Elapsed Time will reset to 0

Time Dosing Options Menu (Time Dose Controllers Only)

Pump # Time On - (Pump Enable Time Setting, # is Pump number (1 or 2))
This is the amount of time the pump will be enabled to run once the level reaches the “Pump On” (simplex) or “Lead On” (duplex) Float. Note: If the level reaches the Pump Off Float before time expires, the pump will shut off and the Pump Disable time will begin.

Time shown is in [Minutes:Seconds] (Maximum time setting is 99:59)

Press Set/Change button to change this field.

Pump # Time Off - (Pump Disable Time Setting, # is Pump number (1 or 2))
This is the amount of time the pump must wait after it completes a run cycle before it may run again. Note: If the level reaches the Override Float (Lag) the pump will begin to run regardless of Pump Disable Time.

Time shown is in [Hours:Minutes] (Maximum time setting is 99:59)
To disable Time Dosing, set this field to 00:00.

Press Set/Change button to change this field.

Pump # Ovrriid On - (Pump Enable Time Setting for Override, # is Pump number (1 or 2))
This is the amount of time the pump will be enabled to run once the level reaches the Override Float, at which time the system enters the Override Time Dosing mode.

Time shown is in [Minutes:Seconds] (Maximum time setting is 99:59)

Press Set/Change button to change this field.

Pump # Ovrriid Off - (Pump Disable Time Setting for Override, # is Pump number (1 or 2))
This is the amount of time the pump must wait after it completes an Override run cycle before it may run again. Note: The pump will continue to cycle in override time dosing mode until the level is below the Override Float when the Override Pump Disable Time expires.

Time shown is in [Hours:Minutes] (Maximum time setting is 99:59)

Press Set/Change button to change this field.

Alarm/Override

This setting controls 3 functions of Time Dosing:

Override: When the basin level reaches the Override float (High Level setpoint on simplex, Lag setpoint on duplex), the panel will override the Off Timer, and run the pump(s) using the override On and Off times.

Override Warning: When an override occurs, the panel will sound an Override Warning Alarm, to signal that an override event is occurring.

High Level Alarm: When the basin level reaches the High Level setpoint, the panel will sound a High Level Alarm, to signal that the liquid level is much higher than expected.

Setting	Override	Override Warning	High Level Alarm
Override w/Alarms	ON	ON	ON
Override-No Warn	ON	OFF	ON
Override-No Alrms	ON	OFF	OFF
Alarm-No Override	OFF	OFF	ON

Press Set/Change button to change this field.

High Level Delay - (High Level Time Delay, Simplex Controllers Only):

The High Level Alarm will delay according to the set time. If the fluid level is above the High Level Float for this length of time without interruption the alarm will begin to sound. Time shown is in [Minutes:Seconds] (Maximum time setting is 99:59)

Press Set/Change button to change this field.

Number of Fields – (Duplex Controllers Only)

The Time Dosing operation can be set up for One Field or Two Fields.

When set to “Two Fields” each pump will be able to run as soon as its corresponding Off Timer is complete. During override the two pumps may run at the same time.

When set to “One Field” each pump will only be able to run when the Off Timer for *both* pumps is complete. The two pumps will never run at the same time.

Telemetry Menu (Modem Option Only)

Call Number

Displays the telephone number the modem will call to report alarms and to check in monthly. This field may hold from 1 to 11 digits.

Press Set/Change button to change this field. Enter the number 1 digit at a time. If entering less than 11 digits, enter a blank character to signify when the telephone number has been entered completely.

Note: This number is set at the factory and will not need to be changed under normal operation.

I.D. Number

Displays the unique identification number assigned to the control panel. This field will not normally need to be edited. (May contain the numbers 0-9 and the characters A-F.)

Press Set/Change button to change this field.

Note: This number is set at the factory and will not need to be changed under normal operation.

Initiate Check-In

Press Set/Change button to force the modem to call in. Emails and text messages will not be sent for this notification. This menu will also display the status of the modem connection.

Alarm History Menu

This menu displays the last three alarms that have occurred, beginning with the most recent alarm. On Titan Controllers equipped with a modem, this menu will also display the date and time the alarm condition occurred.

Auxiliary Inputs

There are three Auxiliary Inputs (labeled 1, 2, and 3) on the DIB, each with its own alarm. Each has a 120Vac input, and all three share a common Neutral. The power to these inputs should come from terminal CF, or a fused 120Vac source; all three inputs must use the same source.

Inputs 1 & 2 are for normally closed contacts, and are specifically used for pump 1 & 2 heat sensor and/or overload. Input 3 is for normally open contacts, and is a general panel alarm.

Input Rating: 120 Vac, 10mA each

Troubleshooting

Each different alarm is annunciated on the LCD screen. The audible and alarm light also flash at different rates for each alarm. The alarm conditions are explained in the chart below:

Alarm/Fault	Alarm Light Flash	Audible Flash	Other Indication
High Level	2 per sec.	2 per sec.	Aux. Contact Closed
Timer Override	1 every 4 sec.	1 every 4 sec.	X
Alarm Power Fail	X	1 every 4 sec.	Alarm Power LED Off Alarm Fuse LED Off
Control Power Fail	1 every 4 sec.	1 every 4 sec.	Control Power LED Off Control Fuse LED Off
Alarm Fuse Fail	X	1 every 4 sec.	Alarm Power LED Off Alarm Fuse LED On
Control Fuse	1 every 4 sec.	1 every 4 sec.	Control Power LED Off Control Fuse LED On
Float Failure	X	X	Float LED Flash
Pump 1 Fault	1 long, 2 short	1 long, 2 short	Pump 1 LED Flash
Pump 2 Fault	1 long, 2 short	1 long, 2 short	Pump 2 LED Flash
Auxiliary Input Alarm	1 long, 2 short	1 long, 2 short	X
Pump 1 is turned Off	X	X	Pump 1 Run LED Flash
Pump 2 is turned Off	X	X	Pump 2 Run LED Flash

FCC Information

The Federal Communication Commission (FCC) has established rules, which permits this device to be directly connected to the telephone network. If this device is malfunctioning, it may also be causing harm to the telephone network; this device should be disconnected until the source of the problem can be determined and until repair has been made. If this is not done, the telephone company may temporarily disconnect service. The telephone company may make changes in its technical operations and procedures; if such changes affect the compatibility or use of this device, the telephone company is required to give adequate notice of the changes. If the telephone company requests information on what equipment is connected to their lines, inform them of the following:

- a) The telephone number the device is connected to.
- b) The ringer equivalence number (REN).
- c) The device uses an RJ11 type jack.
- d) The FCC Registration Number.

The REN (Ringer Equivalence Number) is used to determine the number of devices that may be connected to the telephone line. Excessive RENs on a telephone line may result in devices not ringing in response to an incoming call. In most, but not all areas, the sum of the REN should not exceed five (5.0). To be certain of the number of devices that may be connected to a line, as determined by the total RENs, contact the local telephone company.

Specifications

Float Status	LEDs thru bezel
Dimensions	10.72"h X 9.85"w X 0.76"d
Mounting	Panel Mount, w/ eight 6-32 x 1/2" screws
Weight	1.5 pounds
Alarm Power Input	115Vac
Control Power Input	115Vac
P1, P2 Output	115Vac, 100 mA max.
LT Output	115Vac, 100 mA max.
Aud Output	Open Collector Output, 75mA max.
V+ Output	+12Vdc, unregulated
Float Inputs	120Vac, 10 mA max.
Aux Inputs	120Vac, 10 mA max.
Aux Alarm Contact Rating	120Vac, 5A max.
Fuse Rating	5mm x 20mm, 3 Amps max.
Terminal Torque Ratings	7.0 inch-lbs.
Controller Temp Range	-40°F (-40°C) to +185°F (85°C)
Humidity	95% non-condensing
Non-Conductive Injection Molded Bezel	
Provides NEMA 1 Rating (when mounted through an enclosure)	
Blown Fuse Status Lights	
3 Year Limited Warranty	



CSI Controls, 220 Ohio Street, Ashland, Ohio 44805
 Phone 419-281-5767 · Toll Free 1-800-363-5842 · FAX 419-289-2535
 ©2011 CSI Controls www.CSIcontrols.com csi.info@CSIcontrols.com