



FEATURES:

- Flashing Red Alarm Light
- 2 - Amber Run Lights
- High Decibel Audible (optional)
- NEMA 4X Fiberglass Enclosure
- Stainless Piano Hinged Door
- Stainless Door Latches w/Padlock Hasp
- External Mounting Feet
- Automatic Alternating Relay/Override Circuit
- 3 Pole, Non-Reversing Contactor
- 2 - Adjustable Overload Relays
- 2 - Motor Heat Sensor Connections
- 2 - Motor Seal Fail Circuits
- 2 - "Hand/Off/Auto" Heavy Duty Toggles
- Alarm "On/Off/Test" Heavy Duty Toggle
- Field Wiring Terminal Strips
- 2 - Motor Circuit Breakers
- Control Circuit Breaker
- Individual 3 Amp Control/Alarm Circuit Fuses
- UL 508A Listing (optional)
- One Year Limited Warranty



DSC2230P shown

APPLICATIONS INCLUDE:

Grinder & Non-Clog Pumps for:
 Residential, Commercial & Industrial
 Lift Stations
 Sewage Basins & Tanks
 Pressure Sewer Systems
 And Many More...

AVAILABLE OPTIONS:

Piezo Buzzer

Alarm Bell

Vibrating Horn

(Automatic reset silence circuit included with all audibles)

UL 508A Listing

Specifications - Call for Pricing

Motor Start Components NOT Included

Model	Location Use	Max Full Load Amps	Enclosure Type	Enclosure Material	Input Power VAC -Ph	Audible Included	Control & Alarm Fuses	Max Pump HP	Approx Ship Weight
DSC2230	Outdoor	12	NEMA 4X	Fiberglass	230-1	---	3 Amp	2	38 lbs
DSC2230P	Outdoor	12	NEMA 4X	Fiberglass	230-1	Piezo	3 Amp	2	38 lbs
DSC2230B	Outdoor	12	NEMA 4X	Fiberglass	230-1	Bell	3 Amp	2	39 lbs
DSC2230H	Outdoor	12	NEMA 4X	Fiberglass	230-1	Horn	3 Amp	2	40 lbs

*Add Suffix - FB to Model # If Ordering Float Switch and Float Switch Mounting Bracket Option
 Float Kit Includes (4) MPF-0-10 Float Switches & (1) FSB-SS4 Float Switch Mounting Bracket



Watch Dog Series DSC2230 NEMA 4X Duplex Control

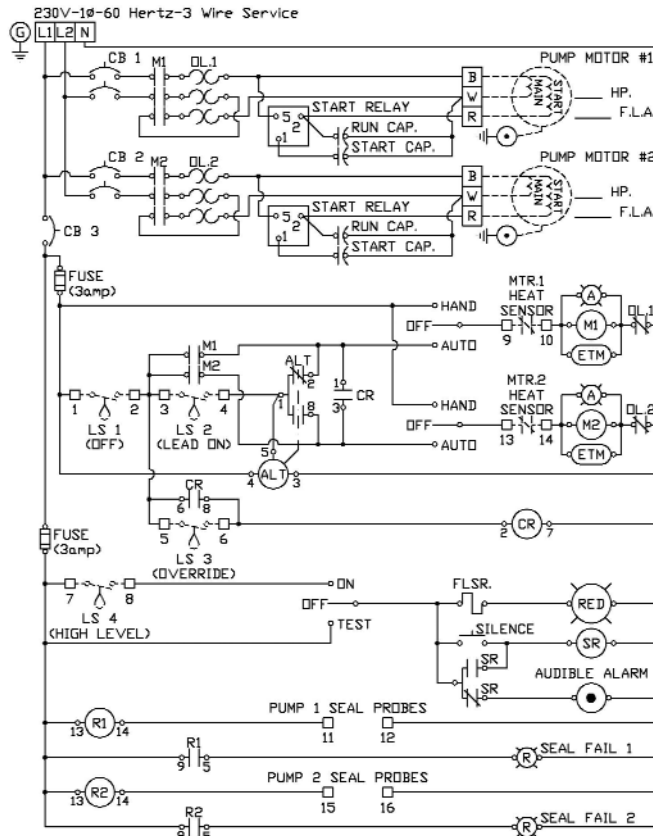

Model #DSC2230 w/Audible

PIEZO AUDIBLE WILL BE MOUNTED THROUGH THE BOTTOM OF THE ENCLOSURE.
 BELL OR HORN AUDIBLE WILL BE MOUNTED ON THE TOP RIGHT-SIDE OF THE ENCLOSURE.

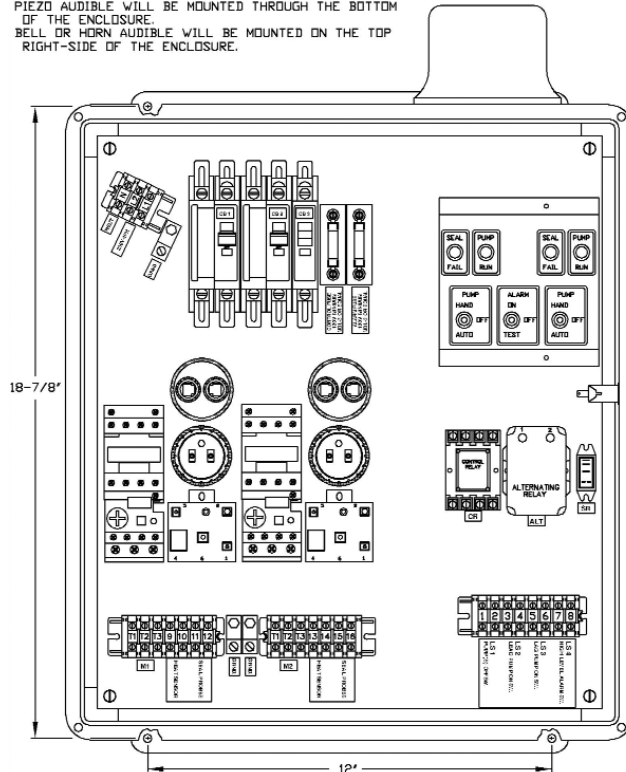

CONTROLS