



## FEATURES:

- Flashing Red Alarm Light
- Amber Run Light
- High Decibel Audible (optional)
- NEMA 4X Fiberglass Enclosure
- Stainless Piano Hinged Door
- Stainless Door Latches w/Padlock Hasp
- External Mounting Feet
- 3 Pole, Non-Reversing Contactor
- Adjustable Overload Relay
- “Hand/Off/Auto” Heavy Duty Toggle
- Alarm “On/Off/Test” Heavy Duty Toggle
- Field Wiring Terminal Strips
- Motor Circuit Breaker
- Control Circuit Transformer - Primary Fusing
- Individual 3 Amp Control/Alarm Circuit Fuses
- UL 508A Listing (optional)
- One Year Limited Warranty

## AVAILABLE OPTIONS:

Piezo Buzzer

Alarm Bell

Vibrating Horn

(Automatic reset silence circuit included with all audibles)

UL 508A Listing



S463P shown

## APPLICATIONS INCLUDE:

- Starting & Stopping Pump for:
  - Sump & Sewage Basins
  - Septic Tanks & Aeration Systems
  - Cisterns & Atmospheric Storage Tanks
  - Chemical Solution Tanks
  - And Many More...

No Motor Heat Sensor  
or Seal Fail Probes

## Specifications - Call for Pricing

Model	Location Use	Max Full Load Amps	Enclosure Type	Enclosure Material	Input Power VAC -Ph	Audible Included	Alarm Fuse	Control Fuse	Approx Ship Weight
S463	Outdoor	18	NEMA 4X	Fiberglass	460-3	---	3 Amp	3 Amp	15 lbs
S463P	Outdoor	18	NEMA 4X	Fiberglass	460-3	Piezo	3 Amp	3 Amp	15 lbs
S463B	Outdoor	18	NEMA 4X	Fiberglass	460-3	Bell	3 Amp	3 Amp	16 lbs
S463H	Outdoor	18	NEMA 4X	Fiberglass	460-3	Horn	3 Amp	3 Amp	17 lbs

\*\*Add Suffix For FLA Requirement (See table on next page)

\*Add Suffix - FB to Model # If Ordering Float Switch and Float Switch Mounting Bracket Option  
Float Kit Includes (3) MPF-0-10 Float Switches & (1) FSB-SS3 Float Switch Mounting Bracket

CONTROLS

# CSI Watch Dog Series S463 NEMA 4X Simplex Control

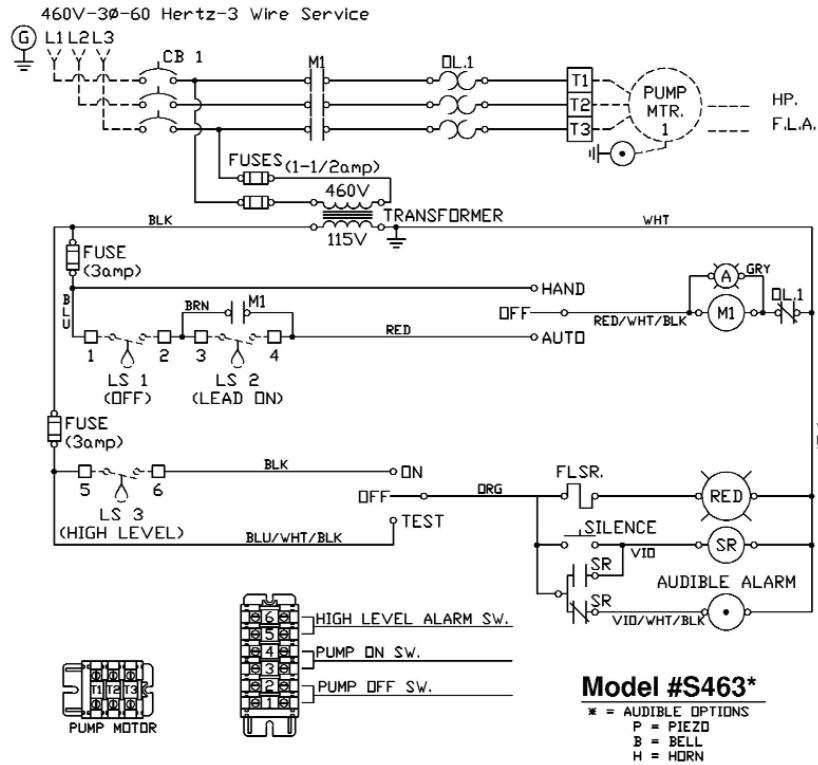

CONTROLS

**\*\*Important\*\***

This "Watchdog" Series panel is for small effluent type pumps only. No provisions for motor heat sensors or seal probes are provided. When ordering any of the above panels, match the full-load-amperes (FLA), of the pump(s) you are using to the chart below and add the proper suffix to the model number. EXAMPLE: You need a simplex control panel with alarm light and bell - your pump is 460 V with FLA rating of 5 - Order Model #S463B-10 for panel only or Model #S463B-10-FB if you want the float kit included

**\*\*FLA Rating Table**

FLA	Suffix	FLA	Suffix
.063-1.0	-05	5.5 - 8	-12
1.0 - 1.7	-06	7 - 10	-14
1.6 - 2.5	-07	9 - 13	-16
2.5 - 4	-08	12 - 18	-21
4 - 6	-10		

