

FEATURES:

- Flashing Red Alarm Light
- 2 - Run Lights
- High Decibel Audible (optional)
- NEMA 4X Fiberglass Enclosure
- Stainless Piano Hinged Door
- Stainless Door Latches w/Padlock Hasp
- External Mounting Feet
- Automatic Alternating Relay/Override Circuit
- 2 - 3 Pole, Non-Reversing Contactors
- 2 - Adjustable Overload Relays
- 2 - Hand Run Pushbuttons
- Alarm Test/Silence Pushbutton
- Field Wiring Terminal Strips
- 2 - Motor Circuit Breakers
- Control Circuit Transformer - Primary Fusing & Breaker
- Individual Control/Alarm Circuit Fuses
- UL 508A Listing (optional)
- One Year Limited Warranty

See Page 15 to learn about the Advantages of the Titan Float System!



APPLICATIONS INCLUDE:

Starting & Stopping Pump for:
 Sump & Sewage Basins
 Septic Tanks & Aeration Systems
 Cisterns & Atmospheric Storage Tanks
 Chemical Solution Tanks
 And Many More...

No Motor Heat Sensor or Seal Fail Probes

AVAILABLE OPTIONS:

- Piezo Buzzer
- (Automatic reset silence circuit included with all audibles)
- Digital Display Center
- UL 508A Listing

Specifications

Model	Location Use	Max Full Load Amps	Enclosure Type	Enclosure Material	Input Power VAC -Ph	Audible Included	Alarm Fuse	Control Fuse	Approx Ship Weight	List Price Panel Only**	List Price Panel w/ Floats & Bracket*
TDF203	Outdoor	18	NEMA 4X	Fiberglass	208-3	---	3 Amp	3 Amp	20 lbs	\$1,605.00	\$1,746.00
TDF203P	Outdoor	18	NEMA 4X	Fiberglass	208-3	Piezo	3 Amp	3 Amp	20 lbs	\$1,679.00	\$1,819.00

**Add Suffix For FLA Requirement (See table on next page)

*Add Suffix - FB to Model # If Ordering Float Switch and Float Switch Mounting Bracket Option

Float Kit Includes (4) MPF-0-10 Float Switches & (1) FSB-SS4 Float Switch Mounting Bracket

To include elapsed time meters & cycle counters a digital display may also be added (\$170 list)

**FLA Rating Table

****Important****
 This Titan Series panel is for small effluent type pumps only. No provisions for motor heat sensors or seal probes are provided. When ordering any of the above panels, match the full-load-amperes (FLA), of the pump(s) you are using to the chart to the right and add the proper suffix to the model number. EXAMPLE: You need a duplex control panel with alarm light and Piezo - your pumps are 208 V with FLA rating of 5 - Order Model #TDF203P-10 for panel only or Model #TDF203P-10-FB if you want the float kit included

FLA	Suffix	FLA	Suffix
.063-1.0	-05	5.5 - 8	-12
1.0 - 1.7	-06	7 - 10	-14
1.6 - 2.5	-07	9 - 13	-16
2.5 - 4	-08	12 - 18	-21
4 - 6	-10		



Titan Series

TDF203 Duplex Float

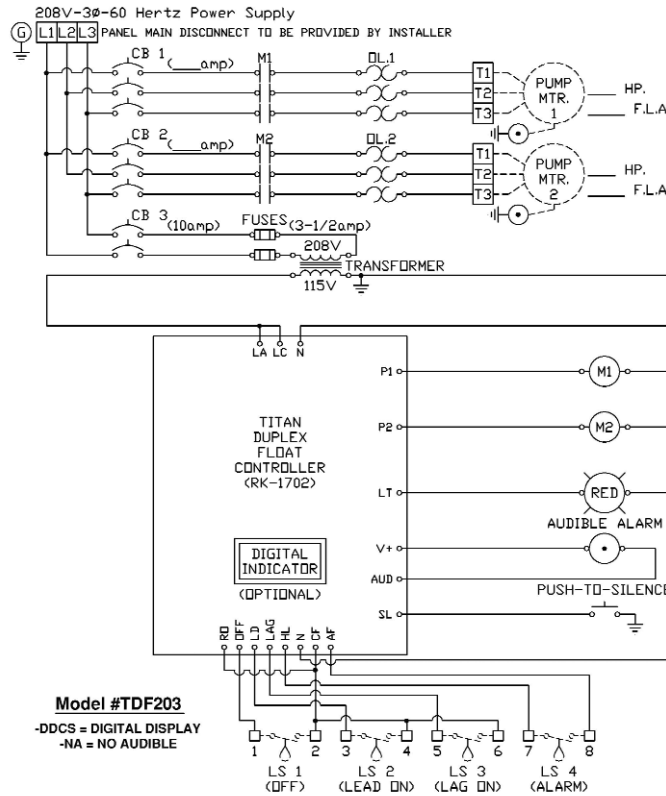

CONTROLS

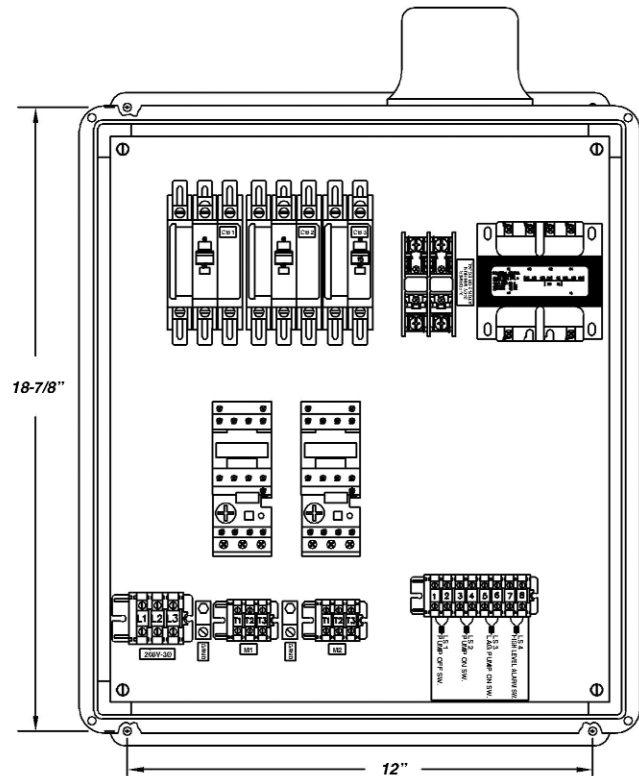
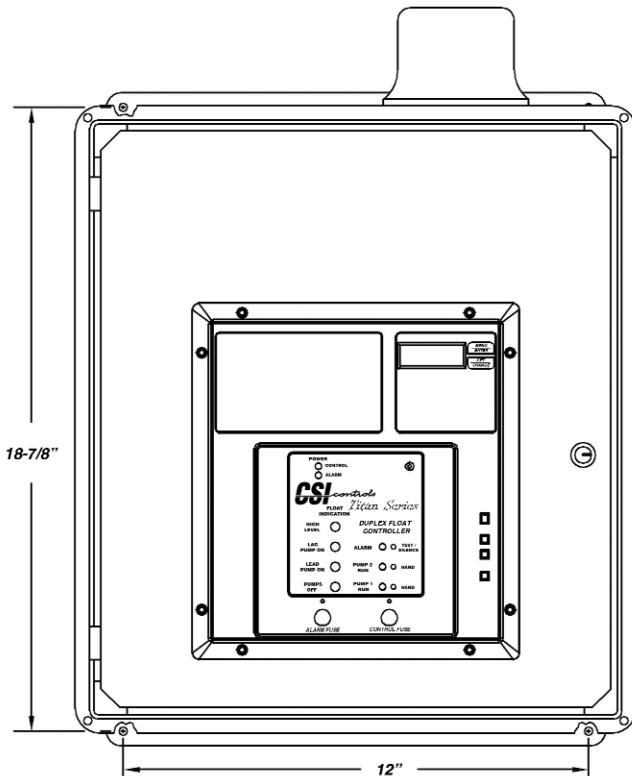

Model #TDF203 w/Audible

AUDIBLE ALARM WILL BE MOUNTED THROUGH THE BOTTOM OF THE ENCLOSURE