

# CSI Titan Series TSP233 Simplex Pressure

## FEATURES:

- Flashing Red Alarm Light
- Run Light
- High Decibel Audible (optional)
- NEMA 4X Fiberglass Enclosure
- Stainless Piano Hinged Door
- Stainless Door Latches w/Padlock Hasp
- External Mounting Feet
- 3 Pole, Non-Reversing Contactors
- Adjustable Overload Relay
- Hand Run Pushbutton
- Alarm Test/Silence Pushbutton
- Field Wiring Terminal Strips
- Motor Circuit Breaker
- Control Circuit Transformer - Primary Fusing & Breaker
- Individual Control/Alarm Circuit Fuses
- UL 508A Listing (optional)
- One Year Limited Warranty

See Page 16 to learn about the Advantages of the Titan Pressure System!



## APPLICATIONS INCLUDE:

Starting & Stopping Pump for:  
 Sump & Sewage Basins  
 Septic Tanks & Aeration Systems  
 Cisterns & Atmospheric Storage Tanks  
 Chemical Solution Tanks  
 And Many More...

No Motor Heat Sensor  
 or Seal Fail Probes

## AVAILABLE OPTIONS:

Piezo Buzzer

(Automatic reset silence circuit included with all audibles)

Digital Display Center

UL 508A Listing

## Specifications

Model	Location Use	Max Full Load Amps	Enclosure Type	Enclosure Material	Input Power VAC -Ph	Audible Included	Alarm Fuse	Control Fuse	Approx Ship Weight	List Price Panel Only(**)(*)
TSP233	Outdoor	18	NEMA 4X	Fiberglass	230-3	---	3 Amp	3 Amp	13 lbs	\$1,161.00
TSP233P	Outdoor	18	NEMA 4X	Fiberglass	230-3	Piezo	3 Amp	3 Amp	13 lbs	\$1,235.00

\*\*Add Suffix For FLA Requirement (See table below)

\*Add Suffix - "MB" to Model # If Ordering Pressure Bell Mounting Bracket (\$45 list) or "TK" for a Tether Kit (\$55 list)

The system comes standard with a pressure bell and 50ft of tubing. More tubing is available (\$.70 per foot list).

To include elapsed time meter, cycle counter, and level read out a digital display may also be added (\$85 list)

## \*\*FLA Rating Table

**\*\*Important\*\***  
 This Titan Series panel is for small effluent type pumps only. No provisions for motor heat sensors or seal probes are provided. When ordering any of the above panels, match the full-load-amperes (FLA), of the pump(s) you are using to the chart to the right and add the proper suffix to the model number. EXAMPLE: You need a simplex control panel with alarm light and Piezo - your pump is 230 V with FLA rating of 5 - Order Model #TSP233P-10 for panel only or Model #TSP233P-10-MB if you want the mounting bracket included

FLA	Suffix	FLA	Suffix
.063-1.0	-05	5.5 - 8	-12
1.0 - 1.7	-06	7 - 10	-14
1.6 - 2.5	-07	9 - 13	-16
2.5 - 4	-08	12 - 18	-21
4 - 6	-10		

# CSI Titan Series TSP233 Simplex Pressure

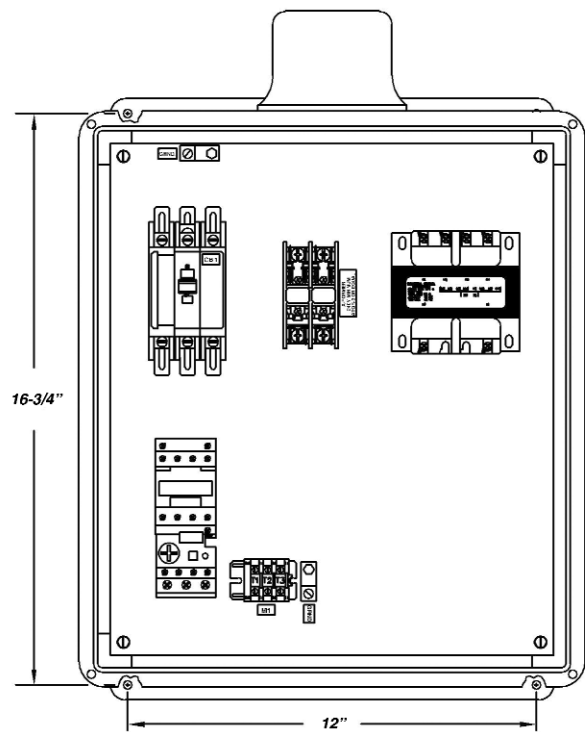
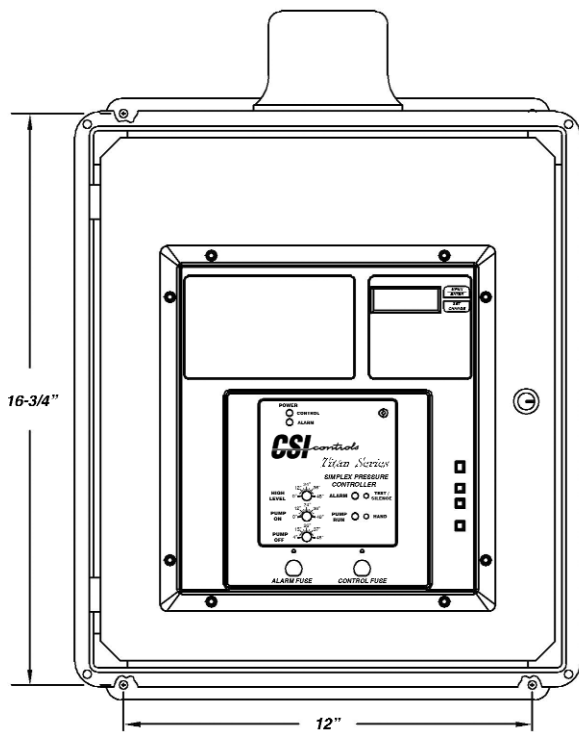
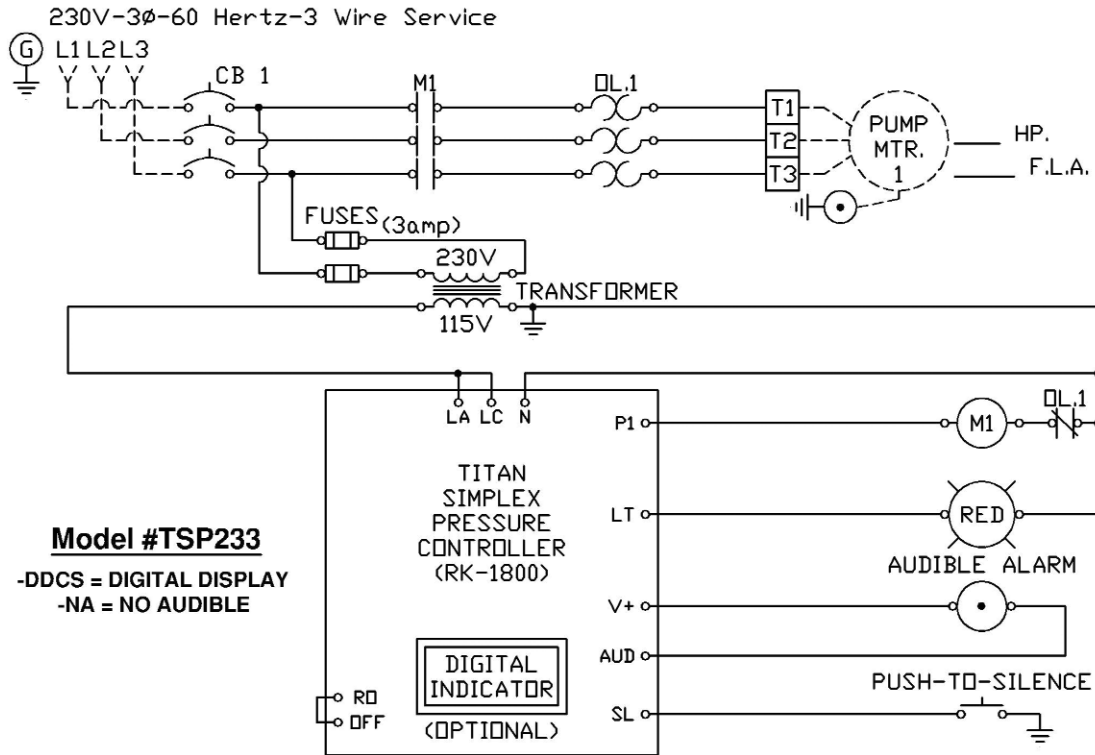

## Model #TSP233 w/Audible

AUDIBLE ALARM WILL BE MOUNTED THROUGH THE BOTTOM OF THE ENCLOSURE