



Watch Dog Series D230 NEMA 4X Duplex Control

FEATURES:

- Flashing Red Alarm Light
- 2 - Amber Run Lights
- High Decibel Audible (optional)
- NEMA 4X Fiberglass Enclosure
- Stainless Piano Hinged Door
- Stainless Door Latches w/Padlock Hasp
- External Mounting Feet
- Automatic Alternating Relay/Override Circuit
- 2 - 3 Pole, Non-Reversing Contactors
- 2 - "Hand/Off/Auto" Heavy Duty Toggles
- Alarm "On/Off/Test" Heavy Duty Toggle
- Field Wiring Terminal Strips
- 2 - Motor Circuit Breakers
- Control Circuit Breaker
- Individual 3 Amp Control/Alarm Circuit Fuses
- UL 508A Listing (optional)
- One Year Limited Warranty

AVAILABLE OPTIONS:

Piezo Buzzer

Alarm Bell

Vibrating Horn

(Automatic reset silence circuit included with all audibles)

UL 508A Listing



D230P shown

APPLICATIONS INCLUDE:

Starting & Stopping Pump for:
 Sump & Sewage Basins
 Septic Tanks & Aeration Systems
 Cisterns & Atmospheric Storage Tanks
 Chemical Solution Tanks
 And Many More...

2 Hp. Max. - Motors With On-Winding Overload Protection

Specifications

Model	Location Use	Max Full Load Amps	Enclosure Type	Enclosure Material	Input Power VAC -Ph	Audible Included	Alarm Fuse	Control Fuse	Approx Ship Weight	List Price Panel Only	List Price Panel w/ Floats & Bracket*
D230	Outdoor	12	NEMA 4X	Fiberglass	230-1	---	3 Amp	3 Amp	19 lbs	\$901.42	\$1,042.38
D230P	Outdoor	12	NEMA 4X	Fiberglass	230-1	Piezo	3 Amp	3 Amp	20 lbs	\$975.13	\$1,116.10
D230B	Outdoor	12	NEMA 4X	Fiberglass	230-1	Bell	3 Amp	3 Amp	21 lbs	\$1,012.03	\$1,152.99
D230H	Outdoor	12	NEMA 4X	Fiberglass	230-1	Horn	3 Amp	3 Amp	21 lbs	\$1,125.36	\$1,266.32

*Add Suffix - FB to Model # If Ordering Float Switch and Float Switch Mounting Bracket Option
 Float Kit Includes (4) MPF-0-10 Float Switches & (1) FSB-SS4 Float Switch Mounting Bracket

Can't Find What You Need Listed Above?

Remember CSI can custom build control panels to meet your specific needs!

CSI Controls™, 220 Ohio Street, Ashland, Ohio 44805 · Phone 419-281-5767 · FAX 419-289-2535

©2009 CSI

www.csicontrols.com

csi.info@csicontrols.com



Watch Dog Series D230 NEMA 4X Duplex Control

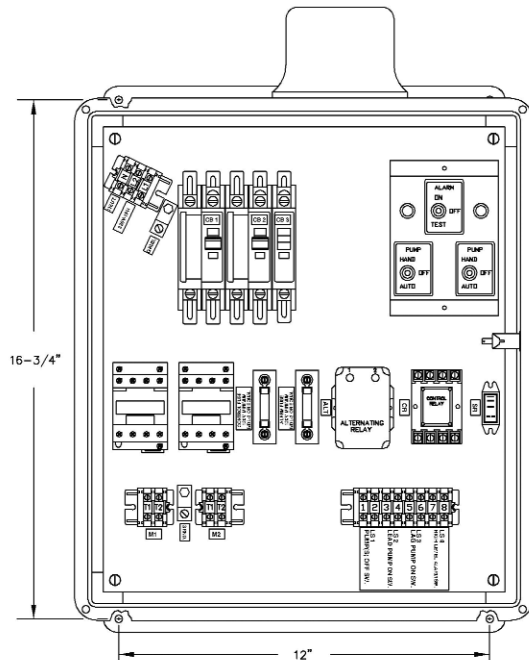
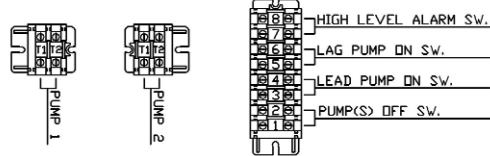
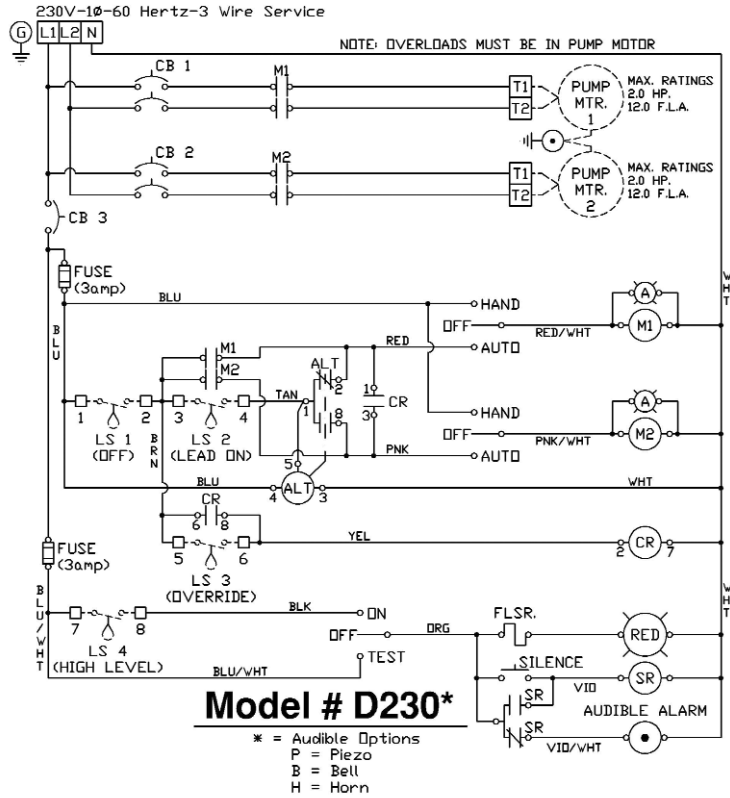

Model #D230 w/Audible

PIEZO AUDIBLE WILL BE MOUNTED THROUGH THE BOTTOM OF THE ENCLOSURE.
 BELL OR HORN AUDIBLE WILL BE MOUNTED ON THE UPPER-RIGHT SIDE OF THE ENCLOSURE.

CONTROLS