



## FEATURES:

- Flashing Red Alarm Light
- 2 - Amber Run Lights
- High Decibel Audible (optional)
- NEMA 4X Fiberglass Enclosure
- Stainless Piano Hinged Door
- Stainless Door Latches w/Padlock Hasp
- External Mounting Feet
- Automatic Alternating Relay/Override Circuit
- 2 - 3 Pole, Non-Reversing Contactors
- 2 - Adjustable Overload Relays
- 2 - "Hand/Off/Auto" Heavy Duty Toggles
- Alarm "On/Off/Test" Heavy Duty Toggle
- Field Wiring Terminal Strips
- 2 - Motor Circuit Breakers
- Control Circuit Transformer - Primary Fusing & Breaker
- Individual 3 Amp Control/Alarm Circuit Fuses
- UL 508A Listing (optional)
- One Year Limited Warranty

## AVAILABLE OPTIONS:

- Piezo Buzzer
- Alarm Bell
- Vibrating Horn

(Automatic reset silence circuit included with all audibles)

UL 508A Listing



D233P shown

## APPLICATIONS INCLUDE:

- Starting & Stopping Pump for:
  - Sump & Sewage Basins
  - Septic Tanks & Aeration Systems
  - Cisterns & Atmospheric Storage Tanks
  - Chemical Solution Tanks
  - And Many More...

No Motor Heat Sensor  
or Seal Fail Probes

## Specifications

Model	Location Use	Max Full Load Amps	Enclosure Type	Enclosure Material	Input Power VAC -Ph	Audible Included	Alarm Fuse	Control Fuse	Approx Ship Weight	List Price Panel Only**	List Price Panel w/ Floats & Bracket*
D233	Outdoor	18	NEMA 4X	Fiberglass	230-3	---	3 Amp	3 Amp	21 lbs	\$1,502.23	\$1,643.19
D233P	Outdoor	18	NEMA 4X	Fiberglass	230-3	Piezo	3 Amp	3 Amp	21 lbs	\$1,576.00	\$1,716.96
D233B	Outdoor	18	NEMA 4X	Fiberglass	230-3	Bell	3 Amp	3 Amp	22 lbs	\$1,612.92	\$1,753.88
D233H	Outdoor	18	NEMA 4X	Fiberglass	230-3	Horn	3 Amp	3 Amp	23 lbs	\$1,726.25	\$1,867.21

\*\*Add Suffix For FLA Requirement (See table on next page)

\*Add Suffix - FB to Model # If Ordering Float Switch and Float Switch Mounting Bracket Option

Float Kit Includes (4) MPF-0-10 Float Switches & (1) FSB-SS4 Float Switch Mounting Bracket



# Watch Dog Series D233 NEMA 4X Duplex Control

CONTROLS

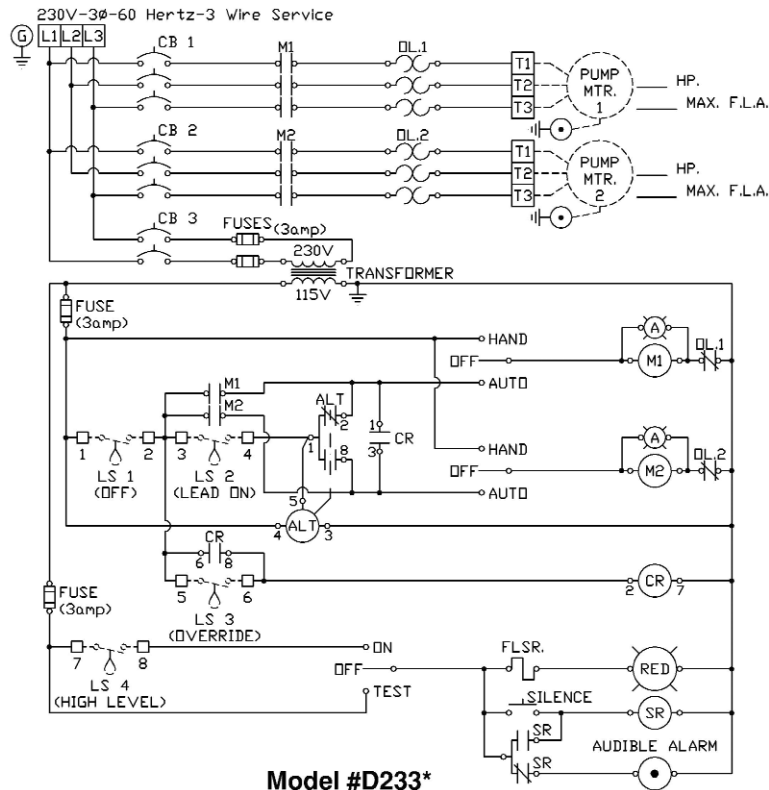

### Model #D233\*

- \* = Audible Options
- P = Piezo
- B = Bell
- H = Horn

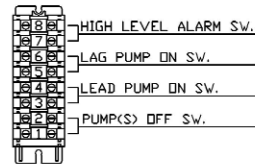

**\*\*Important\*\***

This "Watchdog" Series panel is for small effluent type pumps only. No provisions for motor heat sensors or seal probes are provided. When ordering any of the above panels, match the full-load-amperes (FLA), of the pump(s) you are using to the chart below and add the proper suffix to the model number. EXAMPLE: You need a duplex control panel with alarm light and bell - your pumps are 230 V with FLA rating of 5 - Order Model #D233B-10 for panel only or Model #D233B-10-FB if you want the float kit included

### \*\*FLA Rating Table

FLA	Suffix	FLA	Suffix
.063-1.0	-05	5.5 - 8	-12
1.0 - 1.7	-06	7 - 10	-14
1.6 - 2.5	-07	9 - 13	-16
2.5 - 4	-08	12 - 18	-21
4 - 6	-10		

PIEZO AUDIBLE WILL BE MOUNTED THROUGH THE BOTTOM OF THE ENCLOSURE.  
 BELL OR HORN AUDIBLE WILL BE MOUNTED ON THE TOP RIGHT-SIDE OF THE ENCLOSURE.

