

## FEATURES:

- Flashing Red Alarm Light
- Amber Run Light
- High Decibel Audible (optional)
- NEMA 4X Fiberglass Enclosure
- Stainless Piano Hinged Door
- Stainless Door Latches w/Padlock Hasp
- External Mounting Feet
- 3 Pole, Non-Reversing Contactor
- Adjustable Overload Relay
- “Hand/Off/Auto” Heavy Duty Toggle
- Alarm “On/Off/Test” Heavy Duty Toggle
- Field Wiring Terminal Strips
- Motor Circuit Breaker
- Control Circuit Transformer - Primary Fusing
- Individual 3 Amp Control/Alarm Circuit Fuses
- UL 508A Listing (optional)
- One Year Limited Warranty

## AVAILABLE OPTIONS:

Piezo Buzzer  
Alarm Bell  
Vibrating Horn

(Automatic reset silence circuit included with all audibles)

UL 508A Listing



S203P shown

## APPLICATIONS INCLUDE:

Starting & Stopping Pump for:  
Sump & Sewage Basins  
Septic Tanks & Aeration Systems  
Cisterns & Atmospheric Storage Tanks  
Chemical Solution Tanks  
And Many More...

No Motor Heat Sensor  
or Seal Fail Probes

## Specifications

Model	Location Use	Max Full Load Amps	Enclosure Type	Enclosure Material	Input Power VAC -Ph	Audible Included	Alarm Fuse	Control Fuse	Approx Ship Weight	List Price Panel Only**	List Price Panel w/ Floats & Bracket*
S203	Outdoor	18	NEMA 4X	Fiberglass	208-3	---	3 Amp	3 Amp	13 lbs	\$909.29	\$1,018.75
S203P	Outdoor	18	NEMA 4X	Fiberglass	208-3	Piezo	3 Amp	3 Amp	13 lbs	\$983.06	\$1,092.52
S203B	Outdoor	18	NEMA 4X	Fiberglass	208-3	Bell	3 Amp	3 Amp	14 lbs	\$1,019.95	\$1,129.41
S203H	Outdoor	18	NEMA 4X	Fiberglass	208-3	Horn	3 Amp	3 Amp	15 lbs	\$1,133.29	\$1,242.75

\*\*Add Suffix For FLA Requirement (See table on next page)

\*Add Suffix - FB to Model # If Ordering Float Switch and Float Switch Mounting Bracket Option  
Float Kit Includes (3) MPF-0-10 Float Switches & (1) FSB-SS3 Float Switch Mounting Bracket

# CSI Watch Dog Series S203 NEMA 4X Simplex Control

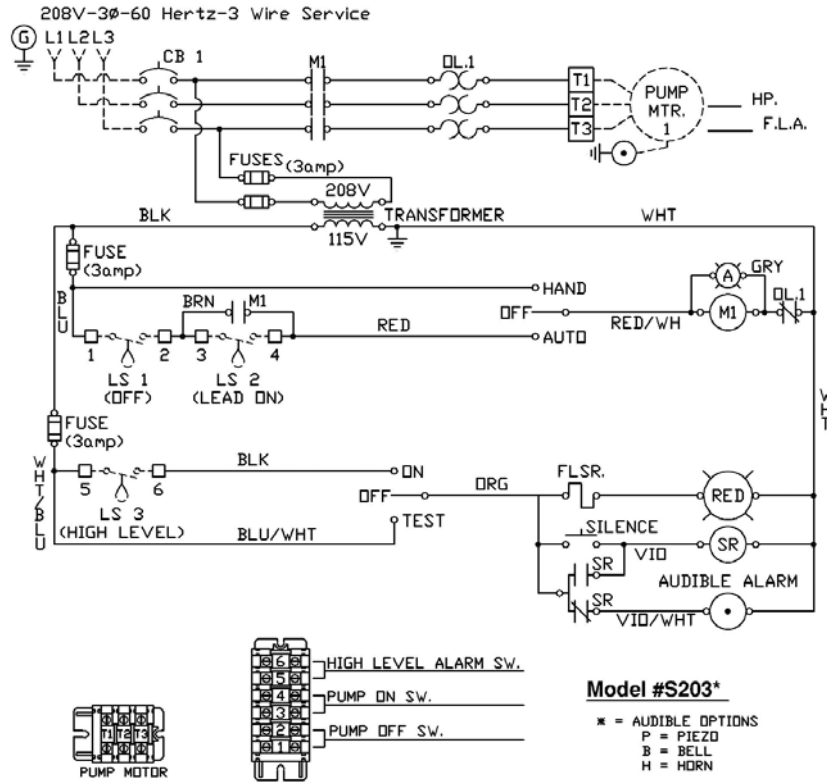

CONNECT GREEN WIRES TO GROUND

**\*\*Important\*\***

This "Watchdog" Series panel is for small effluent type pumps only. No provisions for motor heat sensors or seal probes are provided. When ordering any of the above panels, match the full-load-amperes (FLA), of the pump(s) you are using to the chart below and add the proper suffix to the model number. EXAMPLE: You need a simplex control panel with alarm light and bell - your pump is 208 V with FLA rating of 5 - Order Model #S203B-10 for panel only or Model #S203B-10-FB if you want the float kit included

**\*\*FLA Rating Table**

FLA	Suffix	FLA	Suffix
.063-1.0	-05	5.5 - 8	-12
1.0 - 1.7	-06	7 - 10	-14
1.6 - 2.5	-07	9 - 13	-16
2.5 - 4	-08	12 - 18	-21
4 - 6	-10		

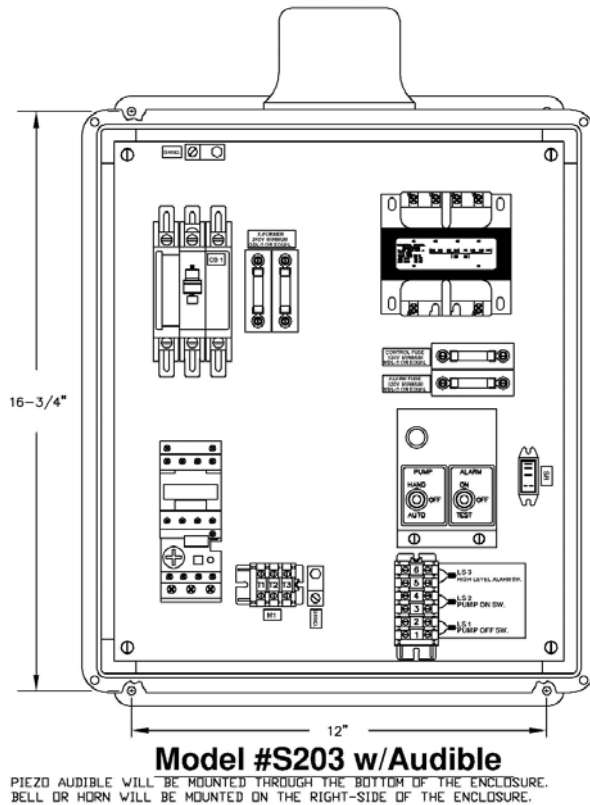

CONTROLS